

Build Your Own TELEVISION RECEIVER

Complete construction details
for a TV receiver that covers
all channels from 44-88 mc.

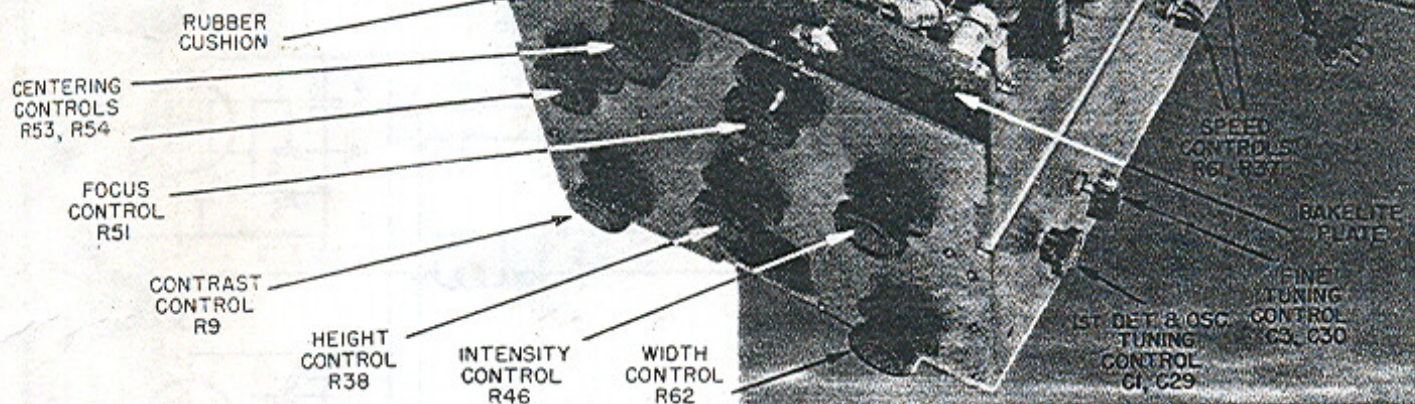

Fig. 1. Top-front view of completed television receiver with video tube shown in place. This unit has been converted from a war surplus type BC-412 oscilloscope. Many of the original components used in the oscilloscope are utilized in this set.

By

LEON S. WECKER and TOM GOOTÉE

AN EXCELLENT home television receiver can be constructed from the principal parts, tubes, and chassis of a low-cost, war-surplus oscilloscope; the type BC-412.

The completed television set has a 5-inch picture tube, self-contained high-voltage and low-voltage power supplies, and a video and sound circuit that is efficient and modern in every respect. Following the first detector stage are four sound stages feeding a PM speaker and five video stages feeding the grid of the cathode-ray tube. Necessary horizontal and vertical sync and control voltages for the picture tube are supplied by conventional circuits.

Using the easily obtained BC-412 war-surplus oscilloscope as the basis for this television receiver, actual cost of conversion is remarkably low, because the normally expensive components—used in the power supplies—are included in the complete oscilloscope unit.

The required scope is an Army Signal Corps type—numbered either BC-412-A or BC-412-B—easily recognizable by its large steel cover and by its excessive weight. It was originally used with the first mass-produced Army radar set (the SCR-268), but is now available at a very nominal price through most radio firms dealing in surplus war equipment.

However, the BC-412 scope selected for conversion must be equipped with a type 5BP4 cathode-ray tube. Some of the available surplus scopes have a tube with a greenish-tinted screen

which is not satisfactory for video reproduction.

This television receiver, designed by Leon S. Wecker, W2FZR, may also be constructed, in the same manner described, using standard parts and components purchased individually. Circuit arrangement and wiring should be relatively the same as shown in accompanying illustrations. The process may be tedious, however. The simplest method of construction is to buy a surplus BC-412 scope and perform the conversion according to these instructions.

In performing any work, adjustment, or repair of television sets and circuits, always take proper safety precautions!

Operating voltages often are as high as several thousand volts. Use tools that are well insulated. Avoid direct contact with any part of a television circuit! Even when the set is turned off, exercise extreme care, since the circuits contain high-voltage condensers that may still be charged.

EDITOR'S NOTE: The techniques used in constructing and servicing television receivers are far removed from those used for AM receivers. Because television receivers are comprised of various intricate circuits it should be borne in mind that in order to successfully construct the unit described in this article one should have had some previous practical experience in the construction of radio equipment.

Whether the set is off or on, don't take chances with high voltage! Death hides in small wires and innocent looking components!

Preparing the Chassis

First step in converting the BC-412 scope is to remove the heavy steel case or cover. Then unscrew and remove the four handle brackets on the chassis.

Examine the main components above and below the chassis, and become familiar with their location and appearance, especially parts associated with the power supplies. A circuit diagram of the scope is glued to the shield surrounding the cathode ray tube, and this diagram can be used to identify parts and components.

Remove all tubes from their sockets, taking care in handling the type 5BP4 cathode-ray tube and its round metal shield.

Next strip and remove all wiring above and below the chassis—with the exception of wiring associated with the low-voltage and high-voltage power supplies and the filament connections. Use a soldering iron; don't cut wires! Some of them may be used later in re-wiring the chassis.

The top portion of the steel front panel is sawed off on a horizontal line that will just clear the tops of the two highest controls when the knobs are in position.

At the bottom center of the steel front panel cut an opening suitable to accommodate a 5-inch PM speaker, and drill mounting holes.

A bakelite or wooden support bracket for the cathode-ray tube should be attached to the top of the large bakelite plate (just behind the steel front panel). Heavy felt or other cushioning material should be used on the top surface of this bracket, so that the tube rests securely.

The chassis is now ready to be re-wired, according to the circuit diagram of Fig. 2.

Use wire having adequate insulation for voltages likely to be encountered. If in doubt, use *heavier* insulation! For all high-voltage leads use ignition cable.

Always allow adequate spacing between adjacent wires, particularly in crowded parts of the receiver. All high-voltage circuits are wired in *above* the chassis.

Use a good grade of solder with rosin core for connections, avoiding cold-soldered joints. Most likely sources of later trouble and defective operation are; badly soldered and loose connections, insufficiently insulated wiring, and improperly shielded and bonded wiring.

C-R-T Control Circuits

First to be mounted and wired are the four variable controls used with

Fig. 2. Complete schematic diagram of the video section of the home-built television receiver. The diagram covering the audio channel for this receiver is shown in Fig. 5.

the high-voltage circuit of the cathode-ray tube. These are the potentiometers controlling; *HORIZONTAL CENTERING*, *VERTICAL CENTERING*, *FOCUS*, and *INTENSITY*.

Mounting holes for seven controls are already positioned in the steel front panel, and the upper four are now used to accommodate the proper potentiometers.

They are mounted behind the large bakelite plate, so that their shafts extend out and pass through the mounting holes in the front panel. These four high-voltage controls *must* be properly insulated from their shafts by means of insulated couplings (Figs. 1 and 3). Original knobs can then be replaced on the four protruding shafts.

Since the high-voltage circuits are wired in *above* the chassis, the height of these four potentiometers makes their position ideal for all wiring. Select the proper values of associated resistors, and connect the high-voltage control circuits according to the circuit diagram.

Use ignition cable for all wiring. Make certain the proper size potentiometers are used for the four panel controls. Note that the resistance value of the *INTENSITY* control is 100,000 ohms.

Nomenclature of the original four controls (printed on the face of the steel front panel) should now correspond to the function of the new television controls.

C-R-T Amplifier Stages

Next to be connected are the *horizontal amplifier* and *vertical amplifier* stages which control the operation of the picture tube.

The two amplifiers are somewhat similar in design, each using a type 6SN7 tube in a stage of phase-inverting amplification and each performing a similar, though independent, function. Saw-tooth waves previously generated by the *horizontal oscillator* stage are amplified by the *horizontal amplifier* and then applied to the horizontal deflecting plates of the picture tube, causing the electron beam to

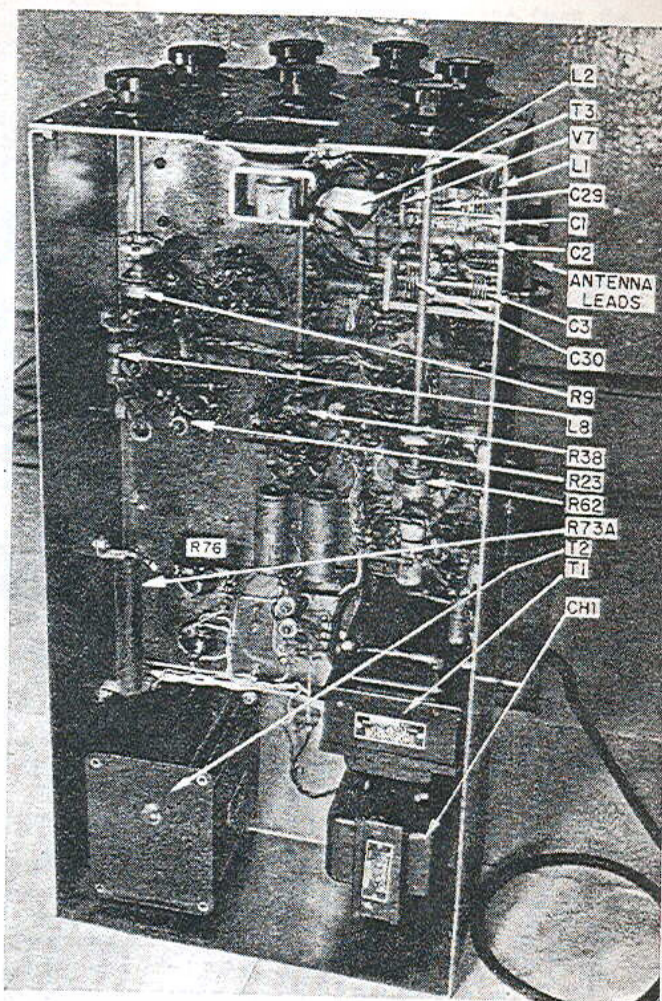

Fig. 3. Under-chassis view of completed receiver. Note that all components are grouped closely to form their respective stages. Sound trap, L, (not visible in the photo), is mounted directly under the tuning condensers, C₁, C₃₀.

sweep horizontally across the face of the tube at a high frequency. Saw-tooth waves previously generated by the *vertical oscillator* stage pass through the *vertical amplifier* and are then applied to the vertical deflecting plates of the picture tube, causing the electron beam to sweep vertically at a lower frequency.

Mount the tubes for the *horizontal amplifier* and *vertical amplifier* close to the cathode-ray tube (Fig. 4). Then wire the two stages according to the circuit diagram.

Bias for the *horizontal amplifier* tube is obtained from the rectified grid current.

Couple the output of each amplifier through the 2500 w.v. condensers (mounted behind the cathode-ray tube base plate and socket), and then connect to appropriate deflecting plates of the picture tube.

C-R-T Oscillator Stages

The *horizontal oscillator* and *vertical oscillator* stages operate similarly but independently, each using a type 6N7 tube in a modified multivibrator arrangement to generate a saw-tooth voltage waveform. The *horizontal oscillator* provides a high-frequency wave which is coupled to the *horizontal amplifier* stage. The *vertical oscil-*

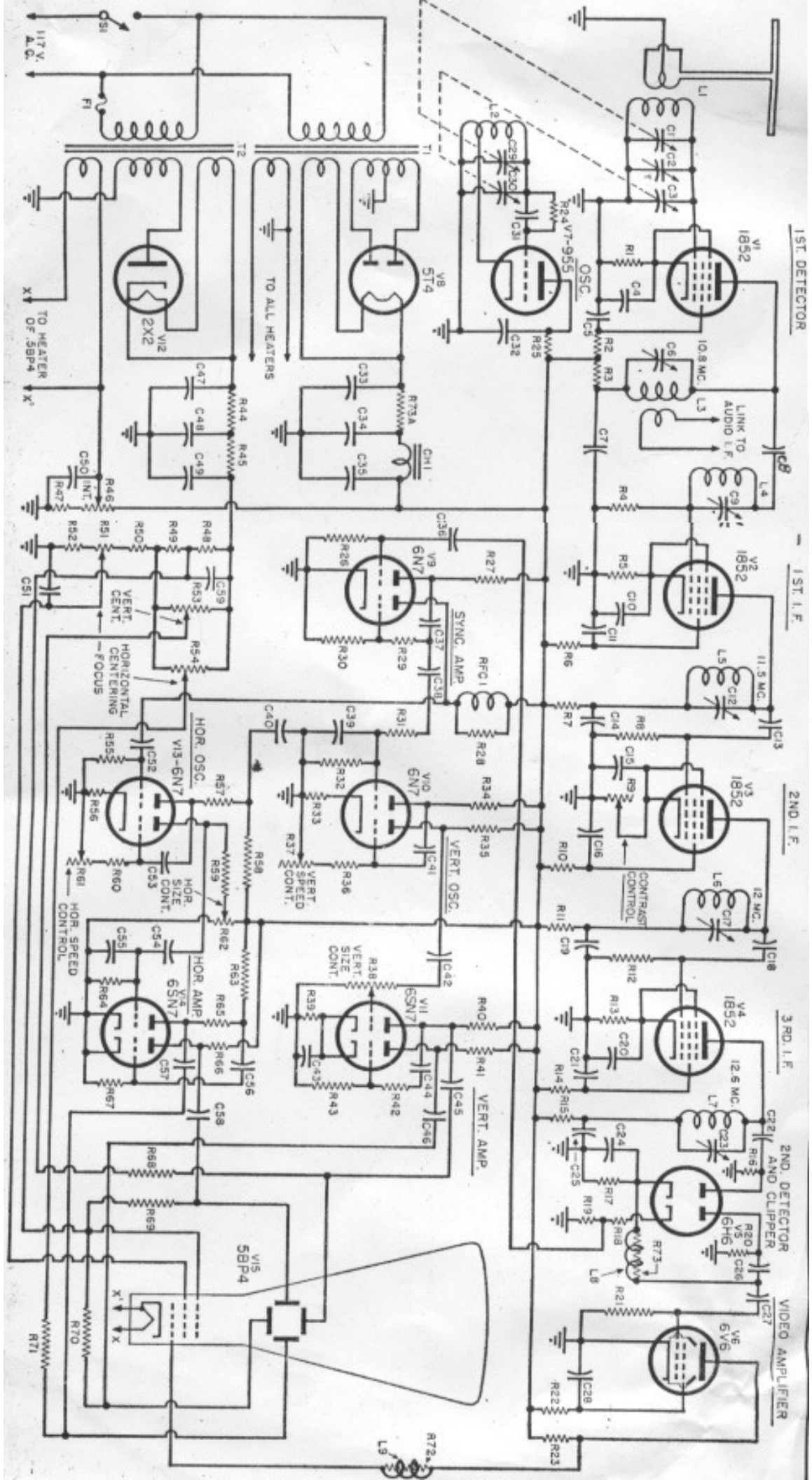

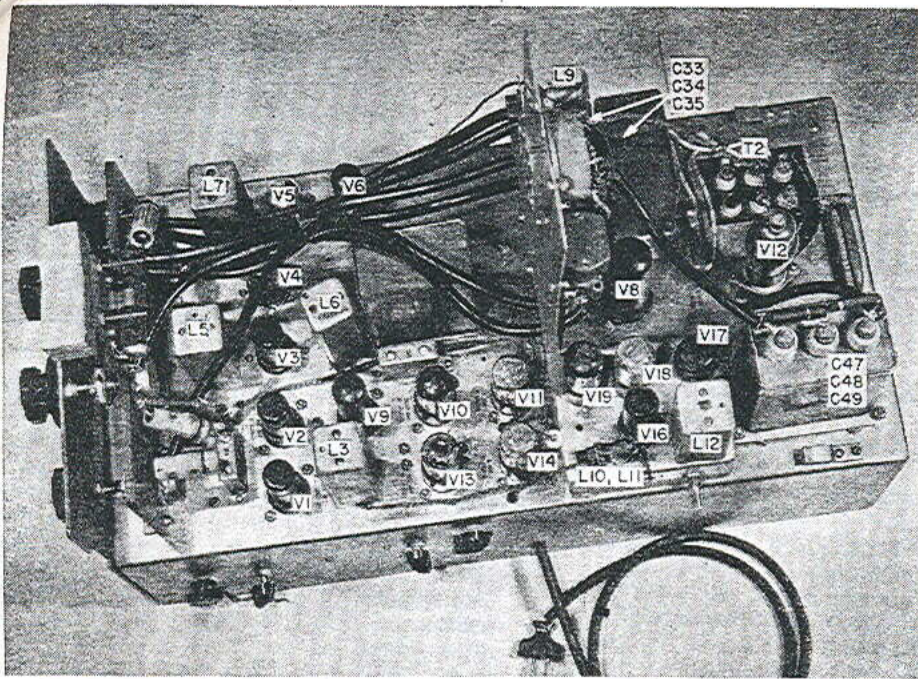

Fig. 4. Top view of completed television receiver, with cathode-ray tube removed. Note cushioned bracket for picture tube. High voltage units are toward rear of the chassis near the actual tube connections. The large, unidentified can, mounted in the center of the chassis, contains a bank of .1 μ d., 600 v. condensers.

Amount of output voltage from the vertical oscillator can be varied by means of a 2 megohm potentiometer known as the VERTICAL SIZE control, or the HEIGHT control. These two controls determine the width and height of the television image on the screen of the cathode-ray tube.

The HEIGHT and WIDTH controls are mounted underneath the chassis, each on a bracket that is part of the steel chassis. Extension shafts with insulated couplings protrude through openings in the lower part of the steel front panel (Fig. 3). Original knobs can be placed on the two protruding shafts, and their panel designations changed to HEIGHT and WIDTH respectively.

Preliminary Test

At this point, a preliminary check of the assembled equipment can be made to test the operation of the scope control circuits.

First, turn all controls on the front panel to the "OFF" position (full counter-clockwise) and apply 110-120 volts a.c. to the power stages.

Turn up the INTENSITY control slowly—until a faint spot appears on the screen of the picture tube.

Then vary the position of the FOCUS control to obtain the smallest and sharpest pin-point of light. However, don't make the spot too bright, since this may seriously damage the screen of the tube.

Next, check the operation of the two centering controls. Any adjustment of the HORIZONTAL CENTERING control should cause a horizontal movement of the spot on the screen. Adjustment of the VERTICAL CENTERING control should cause a vertical movement of the spot. Action of the two centering controls must be independent of each other.

If the spot fails to react to one or more of the four front panel controls, turn off the equipment and recheck all wiring relative to these circuits.

If the spot reacts favorably, advance the HORIZONTAL SIZE or WIDTH control. (Continued on page 134)

lator provides a saw-tooth wave of lower frequency which is coupled to the vertical amplifier stage.

When free-running, each oscillator functions at a frequency determined by the resistance-capacitance balance in the grid and plate circuit. However, when sync pulses from a television transmitter are amplified (by the sync amplifier stage) and applied to the grid circuit of each oscillator, the multivibrator "locks" with the frequency of the incoming sync pulses.

In this manner the horizontal oscillator and vertical oscillator stages produce saw-tooth waves in ratio to each other and in frequency according to the incoming sync pulses from the sync amplifier stage.

Referring to the parts arrangement shown in Fig. 4, the vertical oscillator tube is placed in front of the vertical amplifier tube, and the horizontal os-

illator tube is placed in front of the horizontal amplifier tube.

Wire the two oscillator circuits according to the circuit diagram, after proper controls have been mounted.

The free-running frequency of either oscillator stage is controlled by varying the resistance in the grid circuit. The horizontal oscillator uses a 100,000 ohm variable resistor known as the HORIZONTAL SPEED control. And the vertical oscillator uses a 500,000 ohm variable resistor known as the VERTICAL SPEED control. Mount both controls on the side of the chassis near their respective oscillator tubes so that the grid leads are as short as possible.

Amount of output voltage from the horizontal oscillator is controlled by means of a 500,000 ohm potentiometer known as the HORIZONTAL SIZE control, or the WIDTH control.

Fig. 5. Schematic diagram of the audio section of the television receiver. This channel is link-coupled to the video section.

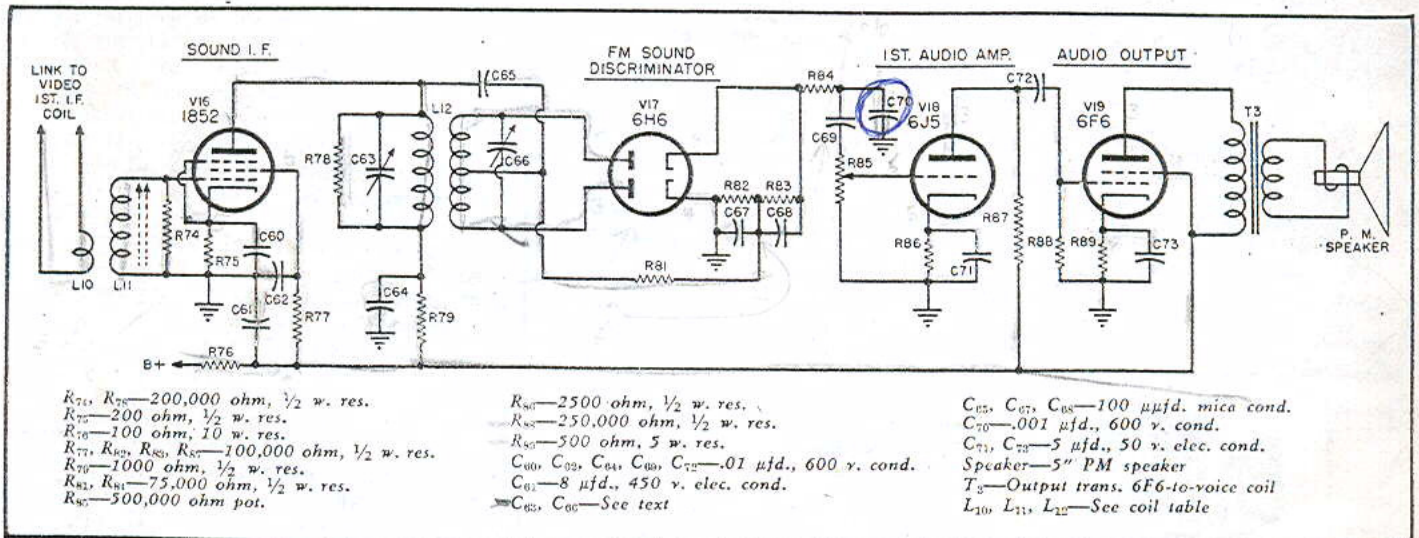

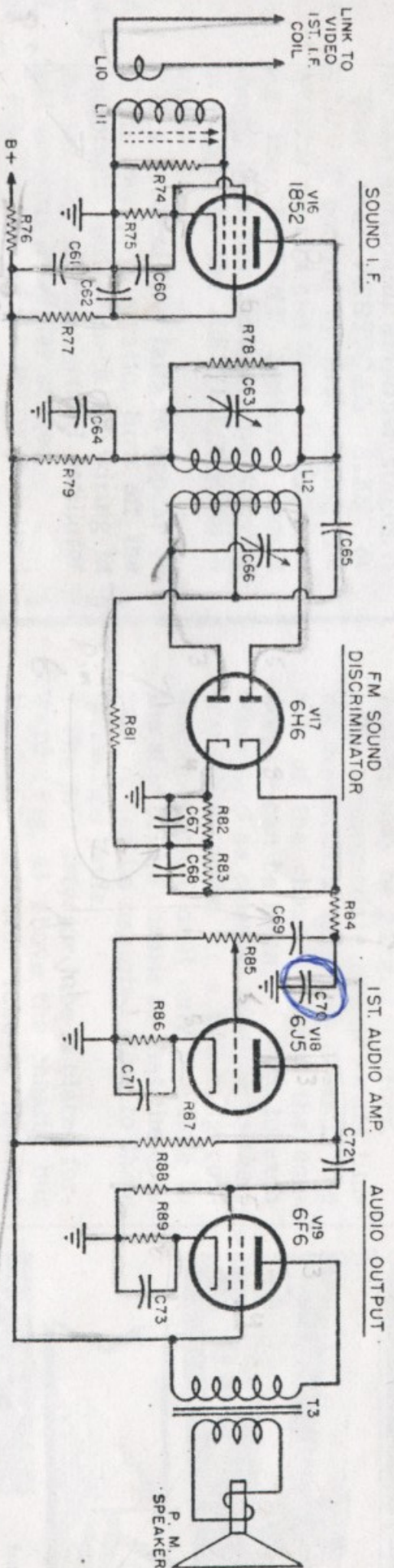

- R_{71}, R_{72} —200,000 ohm, $\frac{1}{2}$ w. res.
- R_{73} —200 ohm, $\frac{1}{2}$ w. res.
- R_{74} —100 ohm, 10 w. res.
- R_{75}, R_{76}, R_{77} —100,000 ohm, $\frac{1}{2}$ w. res.
- R_{78} —1000 ohm, $\frac{1}{2}$ w. res.
- R_{81}, R_{82} —75,000 ohm, $\frac{1}{2}$ w. res.
- R_{83} —500,000 ohm pot.

- R_{84} —2500 ohm, $\frac{1}{2}$ w. res.
- R_{85} —250,000 ohm, $\frac{1}{2}$ w. res.
- R_{86} —500 ohm, 5 w. res.
- R_{87} —500 ohm, 5 w. res.
- R_{88} —01 μ fd., 600 v. cond.
- R_{89} —8 μ fd., 450 v. elec. cond.
- R_{90} —See text

- C_{60}, C_{61} —8 μ fd., 450 v. elec. cond.
- $C_{62}, C_{63}, C_{64}, C_{65}, C_{66}, C_{67}, C_{68}, C_{69}$ —See text
- C_{70} —100 μ fd. mica cond.
- C_{71} —0.01 μ fd., 600 v. cond.
- C_{72} —5 μ fd., 50 v. elec. cond.
- C_{73} —5 μ PM speaker
- T_3 —Output trans. 6F6-10-voice coil
- L_{10}, L_{11}, L_{12} —See coil table

vertically and so provide a good local service. There is some lateral radiation, otherwise you would not have heard us, but we shall shortly try an experiment of using single dipole radiators, and I shall be glad to know when we do this if you receive us better. I will notify you when the change in antenna is made."

Turkey—During the summer, TAP, 9.465, Ankara, has news daily at 1145 instead of 1245 as in winter. *English* periods to Britain are at 1530 on Monday and Thursday, and the *Postbag* period is Sunday at that hour. (Pearce)

U.S.S.R.—Albert E. Langer, Philadelphia, reports Moscow on 17 megacycles (probably 17.765) 0830-1730; broadcasts alternate in French, *English*, and German, with language change every half hour; notes played on half-hour for about 30 seconds; also says the evening North American (*English*) beam can be heard 1820-1950 on 11.63, 11.89, 15.16, 15.41, 15.44, and 1930-1950 on 11.88 and 15.23.

The morning North American beam (*English*) is scheduled 0745-0815 on 11.75, 15.11, 15.17, 15.23, 17.74, and 21.35.

Uruguay—CXA3, 6.075, Montevideo, is heard with good signal in New Zealand, opening at 0500 with "Good Morning" song. (Gray)

Acknowledgements

Thanks for the splendid reports being received this summer. Reports should be mailed to reach your ISW editor by the 5th of any month. QRA is Kenneth R. Boord, 948 Stewartstown Road, Morgantown, West Virginia, U.S.A. Good listening!..K.R.B.

Build a TV Receiver

(Continued from page 48)

control until a thin horizontal line is visible on the screen. As this control is adjusted, the horizontal line should vary in width.

If a horizontal line fails to appear or if the sweep is erratic, turn off the equipment and recheck all wiring in the vicinity of the *horizontal oscillator* and *horizontal amplifier* stages.

Test the *VERTICAL SIZE* or *HEIGHT* control by first closing the *WIDTH* control and then slowly opening the *HEIGHT* control. Result should be a thin vertical line, varying in height as the *HEIGHT* control is adjusted.

If a vertical line fails to appear or if the sweep is erratic, turn off the equipment and recheck all wiring in the vicinity of the *vertical oscillator* and *vertical amplifier* stages.

Finally: Open the *WIDTH* control to a point where the horizontal line on the screen is of optimum width (just within the confines of the edge of the picture tube), and open the *HEIGHT* control so that the image on the screen is of approximately correct height. Then, if the control circuits

have been wired properly, the result on the screen of the picture tube should be an almost-square *raster*.

Next stage to be wired is the *syncronizing amplifier*, using a type 6N7 tube. Function of this stage is the amplification of sync pulses received from the *second detector* stage of the video circuit.

Mount the *sync amplifier* tube in front of the *vertical oscillator* tube (Fig. 4) so that the output of the *sync amplifier* can be coupled conveniently to both oscillator stages.

Two kinds of pulses are required, horizontal sync pulses at a high frequency and vertical sync pulses at a lower rate of repetition. Both kinds are obtained from the single output of the *sync amplifier* by use of suitable *R-C* network filters to provide separation. Method of separation is evident by referring to the circuit diagram.

Horizontal sync pulses must be of higher frequency than the vertical sync pulses. Thus, an *R-C* network (high-pass filter) is used between the *sync amplifier* and the input to the *horizontal oscillator* stage, and another *R-C* network (low-pass filter) is used between the *sync amplifier* and the input of the *vertical oscillator* stage.

In this way the two oscillator stages are synchronized with their respective high- and low-frequencies pulses, and the resultant beam sweep within the picture tube is synchronized with the sync transmissions of any television station to which the *first detector* of the receiver is tuned.

First Detector

The input of the receiver consists of a *first detector* stage using a type 1852 tube, with a *local oscillator* using a type 955 acorn tube. The r.f. oscillator is tuned *above* the frequency of the incoming television signal, and mixing of the two signals produces a strong intermediate beat frequency.

Particularly critical of construction and adjustment is the *first detector* stage and its associated *local oscillator*.

Each of these stages is tuned by a variable 50 μ fd. condenser. They may be tuned individually, or the two condensers may be ganged together.

To accommodate two *separate* tuning condensers, drill two holes in the side of the chassis so that the condensers can be mounted close to each other *and as close as possible to their respective grids*. If a two-gang condenser is used, drill only one hole in the side of the chassis so that the condensers can be mounted *close to their respective grids*.

The *first detector* tube is placed forward (Fig. 4) above the chassis, but the *local oscillator* tube is mounted underneath the chassis just behind the oscillator tuning condenser, so that all leads of the oscillator circuit are as short as possible.

Drill two holes in the chassis above and just behind the oscillator tuning condenser and mount the acorn socket

6/32 stand-off bolts. Height of socket may be adjusted by running two nuts under the socket up to the desired position.

The 100 μ fd. condenser (C_{31}) used in the oscillator grid circuit should be temperature compensated to minimize any frequency shift due to changes in temperature.

The r.f. coils for the first detector and the local oscillator stages are made from No. 14 wire. They are air wound with a diameter of about $\frac{3}{4}$ inch. The exact number of turns cannot be given as the coils will vary in size for each individual case, due to differences in the placement of parts, types of sockets, length of circuit leads, and other common factors. However, in most cases between 3 and 4 turns of wire should be about right.

The cathode of the 955 tube is connected to a point on the oscillator coil L_2 about one turn in from the grounded side of the coil.

Solder the completed r.f. coils to their respective tuning condensers.

The local oscillator functions at a frequency higher than the television signal frequency by an amount that represents the desired intermediate frequency of the video signal; 12.75 megacycles.

Close proximity of the oscillator coil and the first detector coil is sufficient for adequate mixing, and additional coupling is not required to produce a strong beat frequency.

If desired, additional 10 μ fd. fine-tuning condensers (C_3 , C_{30}) can be placed in parallel with the oscillator and first detector main tuning condensers as shown in the circuit diagram. The two fine-tuning condensers should be ganged.

Video Stages

Following the first detector stage of the receiver, the video signal is applied to three video i.f. amplifiers, each stage using a type 1852.

Since the video signal is composed of a very wide band of frequencies, all components of the i.f. amplifier stages must be capable of passing a wide band of frequencies or the definition of the final television picture will be considerably impaired. The chief difficulty in maintaining a broad-band frequency response lies in the construction and adjustment of the i.f. tuning coils.

It may be possible to purchase broad-band i.f. coils at 12.75 megacycles, which would be adequate for use in this receiver.

However, if such coils are not available, they may be constructed without too much trouble.

The best source of parts are old or defective 465 kc. i.f. transformers used in broadcast receivers. These units provide most of the essential units. Unwind the old coils, but keep the coil forms for the new video i.f. coils. Also retain the old assembly bracket, bolts, and shield can.

Intermediate frequency of the video signal is 12.75 mc. To construct a coil for this frequency, wind about 17 turns

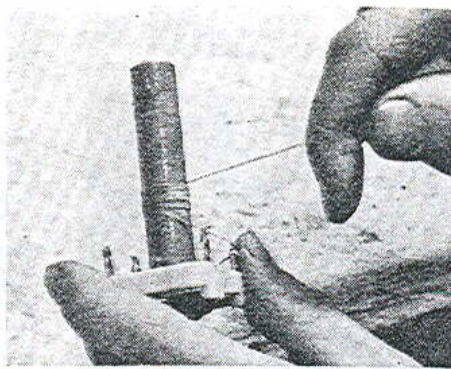

Fig. 6. Photograph shows method of winding i.f.'s on old coil forms. For complete coil specifications see Table 1.

of No. 28 wire on a $\frac{3}{4}$ inch coil form.

The same trimmer condensers used on the old i.f. transformers can be used across the newly wound coil. Since the video i.f. amplifiers pass a wide band of frequencies and are critical, peaked tuning is not necessary.

Mount the rewound coil and trimmer on the assembly bracket. The 1000 ohm filter resistor and the .006 bypass condenser (associated with each video i.f. amplifier stage) are also mounted on the assembly bracket inside the shield can, to conserve wiring space underneath the chassis.

Attach proper leads and then place each video i.f. coil assembly can close to its respective stage, as indicated in Fig. 4.

To prevent sound signals from interfering with the video signals, a wave trap—or "sound" trap—is used between the first detector i.f. coil and the grid of the first video i.f. amplifier tube. The "sound" trap consists of a coil L_4 and condenser C_3 in parallel, and tuned to 8.6 megacycles (the sound i.f. signal). Construct the coil of No. 28 wire wound on a $\frac{3}{4}$ inch form. It is tuned to reject the 8.6 mc. frequency by means of a small trimmer condenser. Connect directly in series with grid of 1st i.f. tube.

All wiring of the first detector and i.f. amplifier stages is now to be completed. But to minimize any tendencies toward oscillation, make all leads as short as possible.

The CONTRAST control—associated with the second i.f. amplifier stage—is mounted on a bracket below the chassis, and an insulated extension shaft protrudes through a mounting hole in the steel front plate of the receiver (Fig. 3).

After suitable amplification, the

Table 1. Coil specifications.

L_1	Pri. 2 t. #28 wire c.t. Sec. 3 to 4 t. #14 wire, $\frac{3}{4}$ " diam. (See text)
L_2	Osc. coil 3 to 4 t. #14 wire, $\frac{3}{4}$ " diam. (See text)
L_3	I.f. trans. Pri. 17 t. #28 wire on $\frac{3}{4}$ " diam. form. Sec. 2 t. #28 wire link
L_4	Sound trap 25 t. #28 wire on $\frac{3}{4}$ " diam. form
L_5, L_6, L_7	I.f. trans. 17 t. #28 wire on $\frac{3}{4}$ " diam. form
L_8, L_9	Peaking coils 50 t. #32 wire wound on 2 w., 500,000 ohm resistor
L_{10}, L_{11}	Sound i.f. Pri. 2 t. #28 wire link Sec. 25 t. #28 wire on $\frac{3}{4}$ " diam. form
L_{12}	Discriminator trans. Pri. 25 t. #28 wire on $\frac{3}{4}$ " diam. form; Sec. 25 t. #28 wire c.t.

video i.f. signal is applied to a second detector and clipper stage using a type 6H6 double diode. Output of this stage is R-C coupled to the final stage: a video amplifier using a type 6V6 beam power tube.

Connect the second detector and clipper stage and the video stage according to the circuit diagram, but do not complete wiring of the plate circuit of the final, output stage.

Peaking coils L_8 and L_9 may be used, as indicated in the diagram, to bring up the higher frequencies for better picture definition. They are simply 2 watt, 500,000 ohm resistors, R_{12} and R_{13} , with 50 turns of No. 32 wire wound on them.

The video circuit of the television receiver is now ready to be aligned and tested.

Video Alignment

Using a signal generator with an output meter or loudspeaker, the video i.f. amplifiers are aligned in conventional manner.

The i.f. stages are stagger tuned, that is, the first coil is tuned to 10.8 mc. for maximum output, the second coil is tuned to 11.5 mc., the third coil is tuned to 12.0 mc., and the fourth i.f. coil is tuned to 12.6 mc.

Connect the output or loudspeaker across the output of the final video amplifier. Short out the tuning condenser of the local oscillator, and turn the CONTRAST control up (clockwise).

Then attach the leads from the signal generator between the grid of the first detector and ground, and adjust the signal generator for maximum output.

Tune each i.f. coil assembly for maximum output from each stage. Changes in some or all of the i.f. coil windings may be found necessary. Alignment procedure should be repeated several times.

If no signal is indicated in the output of the video circuit, turn off the set and carefully recheck the wiring and construction of all video stages. Start with the final amplifier and work back, step-by-step, to the first detector—until the trouble is found.

After the i.f. coil assemblies of the video circuit have been properly aligned, disconnect the signal generator and output indicator and remove the short across the oscillator tuning condenser. Then connect the output of the video amplifier to the grid of the cathode-ray tube, according to the circuit diagram.

The video circuit is now ready to receive a television picture.

First, make certain that a local television transmitter is on the air, preferably a station operating on one of the higher frequency channels. Then tune the receiver to the station. Adjust the trimmer across the tuning condenser of the first detector for maximum picture brilliance. Controls on the front panel are used to bring the picture into sharp focus and desired intensity.

If no picture is visible on the cath-