

DU MONT Instrument Journal

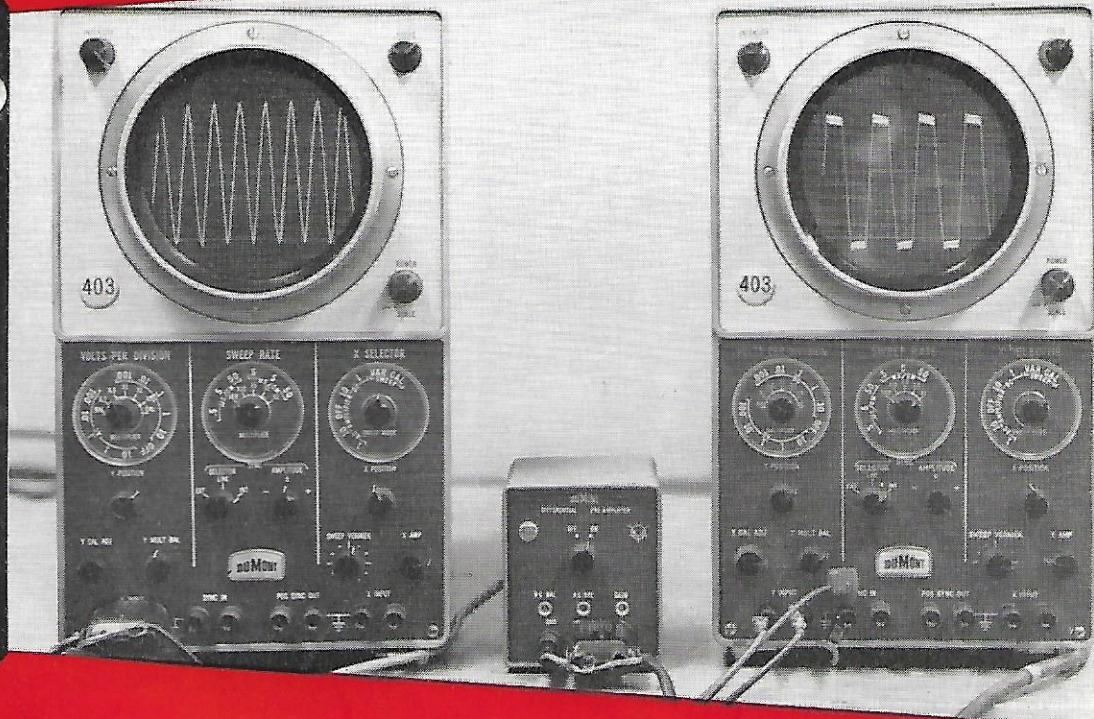

DU MONT

INSTRUMENT DIVISION



A PUBLICATION DEVOTED TO ELECTRONIC INSTRUMENTATION AND RELATED FIELDS, PROVIDING THE LATEST INFORMATION ON DEVELOPMENTS IN EQUIPMENT, APPLICATIONS AND TECHNIQUES. PERMISSION FOR REPRINTING ANY MATERIAL CONTAINED HEREIN MAY BE OBTAINED BY WRITING TO THE EDITOR AT THE ADDRESS BELOW.

PUBLISHED QUARTERLY & COPYRIGHT 1958 BY
ALLEN B. DU MONT LABORATORIES, INC.
TECHNICAL PRODUCTS DIVISION
760 BLOOMFIELD AVE.
CLIFTON, N. J.

EDITOR - ARTHUR HOYT
CONSULTING EDITOR -
NEIL UPTEGROVE

On the Cover

A clipped 60 cps sinewave is added as a common-mode signal to a balanced sinewave; as shown on the oscilloscope to the right. This signal is fed into the transistorized Type 407 Pre-amplifier in the center, the output of which is shown on the oscilloscope to the left. The clean result pictorially displays the common-mode rejection feature of the Pre-amplifier (can be adjusted up to 1,000,000:1) as well as its x10 amplification capability. A theoretical and practical application story on common-mode signal rejection appears on page 9 of this issue.

In the next issue, we will introduce the winner of the contest sponsored by us at the 1958 IRE Show. At the time of printing, entries are still coming in—so that the recipient of the portable Du Mont television set (first and only prize) is still a mystery to us. The winning solution of the three dimensional scope display will be published, as well as the exact method used by us at the show.

Table of Contents

Feature Article

	Page
"Concerning Pulse Channels"	3
Particularly Those in Oscilloscopes	

A discussion of the relationship between the steady state and transient response of a linear channel. The article deals with such things as general and optimum requirements for the oscilloscope pulse channel, amplitude bandwidth, maximum rate of build up, delay distortion and phase bandwidth of linear channels.

Development

"Pre-amplifier With High Common Mode Signal Rejection"	9
--	---

A technical definition and derivation of common mode signal rejection, and the application of its principle in a commercially available transistorized preamplifier.

Research and Application

"Accelerometers and Acceleration Measurement"	12
---	----

A survey discussion, in prose and tabular form, of sundry accelerometer principles and their general characteristics.

Regular Features

Who and Why, Rush S. Drake	8
Vinyl Plastic D.I.J. Binders	14
New Appointment, Leon Seldin	15
Editor's Page	15

CONCERNING PULSE CHANNELS

Particularly Those in Oscilloscopes

by: William J. Judge

Section Manager: High-Frequency Instruments
Du Mont Instrument Division

This article discusses the relationship between the steady state and transient response of a linear channel. Although the oscilloscope pulse channel is emphasized, the fundamentals covered are adaptable for basic analysis of any channel having monotonic amplitude and relative phase characteristics. The article deals with such things as general requirements for the oscilloscope pulse channel, amplitude bandwidth, the maximum rate of build up, delay distortion, phase bandwidth of linear channels, and the optimum characteristic for an oscilloscope pulse channel. Part II of this two-part article will appear in the next issue.

A. General Considerations

The requirements imposed on any information channel are determined by the application. In communication systems, for example, the maximum channel width is often dictated by spectrum conservation considerations and the equipment design is generally complicated by the necessity to restrict the width of the channel.

In oscillography the engineer is usually faced with an entirely different situation—namely—the requirement to optimize the gain-bandwidth product so that *the available energy spectrum is most efficiently employed*. Yet, in spite of the difference in the two applications, there exists between them and the design of any information channel an obvious common denominator — that is — the requisite for deliverance at the output terminals of the channel a reasonable

facsimile of the information appearing at the input. The degree of tolerable distortion will simply be a function of the application. For instance, voice channels can retain intelligence despite the presence of severe distortion — visual channels must be relatively better.

An oscilloscope is a peculiar type of visual information channel in that by tacit agreement between designer and user the channel response to a rectangular impulse (Fig. 1a) ideally manifests distortion only in regard to build up and decay time (Fig. 1b). Since the width of the impulse can be undefined, the channel must be low-pass and is generally direct coupled.

What, then, constitutes the optimum pulse channel characteristic for an oscilloscope? Well, in addition to the low-pass requirement the ideal response to a rectangular impulse might

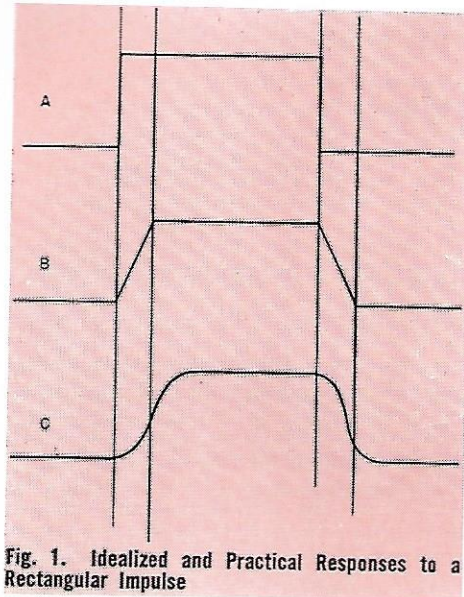

Fig. 1. Idealized and Practical Responses to a Rectangular Impulse

possibly be considered to be that which approaches most nearly the shape shown in Fig 1b; i.e. a build up from zero to steady-state level during any desired time and an identical decay. The curve 1b, of course, is discontinuous between steady-state values and its area conforms to 1a, therefore, an infinite bandwidth is implied since no energy is lost. However, Fig. 1c, illustrates a practical channel response to a rectangular impulse which has a build-up and decay form similar to a half cycle of sine wave and its area is less than that of 1(a) denoting finite bandwidth.

Since a finite bandwidth must be conceded for any physical system, the principle requirement, therefore, for an oscilloscope pulse channel remains the optimum reproduction of a rectangular impulse within the confines of the available energy spectrum. Not only must symmetry of the driving signal be preserved, but minimum build-up time realized without benefit of preswing and overswing. Such a channel ideally will satisfy the following conditions:

- a. Constant phase delay
- b. The transfer modulus is maximum at zero frequency

- c. The transfer modulus first derivative is zero only at zero frequency.

Items a, b, and c are the necessary, but not the sufficient conditions for the development of a response which approaches most nearly the ideal of Fig. 1b. For example, a rectangular (flat-top) channel satisfies all three conditions, but its response to a step-wave oscillates about the steady-state levels (Fig. 4). Furthermore, like an undefined energy spectrum, the condition (a) and usually (c) are non-physical. The extent to which they are satisfied will determine the channel quality.

Constant phase delay (condition a) guarantees symmetrical preservation of the driving signal and should be realized at least for the first 90% of the channel energy spectrum. Conditions b and c simply state that not only must the channel amplitude characteristic never exceed its value at zero frequency, but once it starts falling it must continue to fall with zero amplitude as the limit. As a practical matter, these latter conditions constitute things which are both simply realizable (example—an n-stage uncompensated RC amplifier) and good oscilloscope design practice (a monotonically decreasing response characteristic is usually specified).

The synthesis of the channel characteristic having an impulse response most nearly like that of Fig. 1b is no mean engineering problem. The parasitic capacitances associated with the physical channel serve as the basic limitation on its energy spectrum and maximum rate of build-up. The channel is considered as having a figure of merit — the gain-bandwidth product — and one may be improved only at the expense of the other. Whatever the figure of merit is, and it will generally be a function of the class of oscilloscope, it is the duty of the engineer to optimize the channel response. Consequently, even though preswing and overswing may ideally be undesirable, a minute amount is

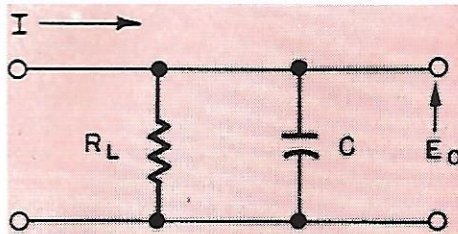

Figure 2. Load shunted by parasitic capacity, usually specified. The existence of one without the other, however, indicates a non-linear phase delay and is wasteful since the build-up time is not minimized.

Some understanding of certain fundamental concepts is required before the synthesis may be attacked. For a given energy spectrum, an undefined number of envelopes and impulse responses being possible, the problem is to select that response which most nearly approaches that of Fig. 1b. Thus, our purpose here is to demonstrate those concepts and develop the "optimum" channel characteristic for an oscilloscope, but we will always keep in mind that convention is heavily involved; even though the subsequent choice of response may satisfy convention, it is nevertheless quite arbitrary.

B. Constancy of the Energy Spectrum - Bandwidth

In low-pass systems, the limitation on the energy spectrum is always the parasitic capacity C. Consider the simple case (fig. 2) of the load resistance R_L shunted by the parasitic capacity C and driven by a constant current generator. The energy developed across this impedance is determined by the real part of the impedance function¹ and is given by the so-called resistance-integral (1) which is independent of the magnitude

$$(1) \int_0^{\infty} R d\omega = \frac{\pi}{2 C}$$

of R_L . Furthermore, if the network of Fig. 2 is modified so as to shape

1. Bode, H. W., Network Analysis & Feedback Amplifier Design, pp 280
2. Bode, H. W., Network Analysis and Feedback Amplifier Design, pp 362

the energy spectrum by the insertion of the optimum passive coupling network, N (see Fig. 3), the area under the response curve will never exceed the value given by equation (1). This is naturally so since energy gain in a passive system is impossible. If the coupling network N is of the minimum reactance - minimum susceptance type, then the energy spectrum is as given by (1); if N contains poles and zeros, then the resultant spectrum is less than $\frac{\pi}{2C}$.

Although the area under the spectrum envelope is dependent only on C, the distribution of the envelope frequency-wise is a function of R_L for a fixed area. The concept of bandwidth may now be introduced. Bandwidth can be a very arbitrary term since the energy spectra of physical channels extends to undefined frequencies. There is fair logic, however, in defining the band-width of a low-pass channel as being the upper limit frequency of a flat-top spectrum envelope having the same area and R_L of the physical channel. That definition permits one to derive a very useful expression for the band-width of the system of Fig. 3. If the network N is non-dissipative (evidently the optimum condition) the power delivered by the generator, $I^2 R$, will be the same as the power dissipated in the load, $I_L^2 R_L$. Therefore, the following expression is certainly valid²—

$$(2) \left| \frac{E}{E_L} \right| = \left| \frac{R}{R_L} \right|^{1/2}$$

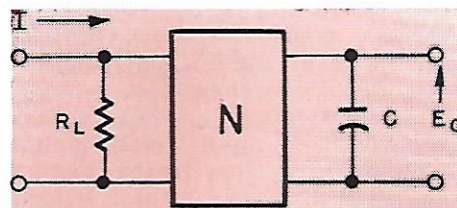

Figure 3. Load coupled to parasitic capacity via optimum network, N.

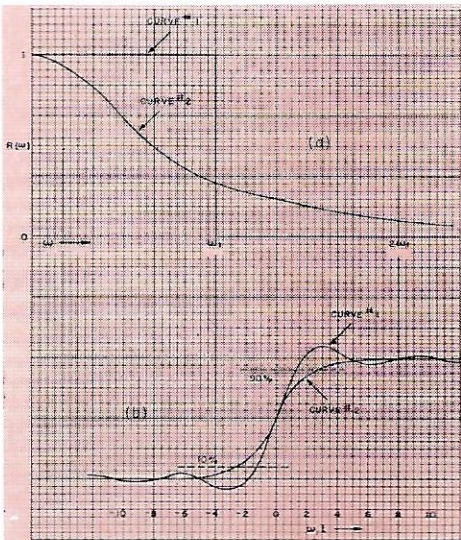

Fig. 4. Envelope Shape (a) and Step Response (b) of two channels having identical Energy Spectra.

If we let $e^\alpha = \frac{E}{E_L}$ (the transmission ratio), then direct substitution of (2) in (1) results in

$$(3) \int_0^\infty e^{2\alpha} d\omega = \frac{\pi}{2CR_L}$$

Equation (3) implies a response characteristic which extends over the complete frequency spectrum, but for a flat-top $e^{2\alpha}$ is uniform up to some frequency and zero outside of that range. This permits us to replace the limits of integration in (3) thus —

$$(4) \int_0^{\omega_1} e^{2\alpha} d\omega = \omega_1 = \frac{\pi}{2CR_L}$$

$$\text{Likewise, } f_1 = \frac{1}{4CR_L},$$

where f_1 represents the bandwidth of a given C and R_L and the optimum coupling network, N .

The conventional definition of band-width, of course, relates to the half-power frequency of the channel; but since a channel having a fixed energy spectrum and a given R_L can have an undefined number of envelope shapes, the half-power definition often fails to adequately describe the

channel capabilities. The full significance of defining the bandwidth of a practical channel as the upper frequency limit of a flat-top having identical energy spectrum and R_L will be demonstrated later.

Equation (4) formalizes a statement made in Section A concerning the figure of merit (gain-bandwidth product) of a channel. Note that the product $\omega_1 \times R_L$ equals the area under the channel envelope; thus the figure of merit of a channel is simply its energy spectrum.

C. Build-Up Time - Constancy of the Maximum Rate

The response of a physical low-pass channel to be a step wave will always manifest a finite build-up time. The form of the transition between steady-state levels of the step-wave is a function of three things; namely, (a) the channel band-width (as defined in Section b), (b) the shape of the channel envelope, (c) the phase delay. Temporarily, at least, the phase delay may be taken as constant and therefore not a factor.

A further simplification occurs when one considers only channels having equal bandwidths. Certainly, then, the transition may take on an indefinite variety of forms since the number of possible envelope shapes is limitless.

Figure 4, which shows the step responses of two channels having constant phase delay and equal bandwidths, but different envelope shapes, illustrates the point. Since each transition is continuous, its time derivative (rate of build-up) is also continuous and has some maximum value which occurs at the half-amplitude point. Although the rate of build-up of the two transitions time-wise is apparently different, each has the same maximum rate of build-up. This is an important relationship which exists between channels having equal areas under their spectra envelopes, and while it is not simply demonstrated, it is worthwhile to do so.

Any complex waveform may be expressed as a sum of sine and cosine terms having various amplitude and phase relationships. A symmetrical wave has in-phase relationships between all its components and is composed only of cosine terms, while a skew-symmetrical wave contains only sine components (again all are in-phase).

A step-wave, therefore, consists of an undefined number of sine terms in-phase, and since the period is also undefined, the spectrum of the step wave is a continuous function. Each sine term has a normalized amplitude given by³

$$b(\omega) = \frac{1}{\pi\omega R_L} \quad (5)$$

and if all the terms are added together from zero to undefined frequency, the step-wave results, represented thus by the Fourier integral:

$$(6) \quad f_s(t) = \int_0^\infty b(\omega) \sin\omega t \, d\omega \\ = \frac{1}{\pi R_L} \int_0^\infty \frac{\sin\omega t \, d\omega}{\omega}$$

to which must be added the DC component $\frac{1}{2 R_L}$ since the step-wave is unidirectional.

Let us consider now the hypothetical case of a channel having a finite low-pass energy spectrum with constant phase delay — the shape of the spectrum envelope can be anything. If this channel is driven by a step-wave having the sine components, $b(\omega) \sin\omega t$, their inflection points are all in phase at $t=0$ corresponding to the mid-point of the step. Now the slope (rate of build-up) of any sine wave at the inflection point is the product of frequency and amplitude⁴ — i.e.

$$(7) \quad \frac{d}{dt} [b(\omega) \sin\omega t] = \omega b(\omega) \cos\omega t \\ = \omega b(\omega) \text{ @ } t = 0.$$

If the real part of the channel characteristic is given by $R(\omega)$ then the maximum rate of build-up of the channel response to any sine component will be $R(\omega) \omega b(\omega)$.

But (5) tells us that each sine component amplitude $b(\omega)$ is equal to $\frac{1}{\pi\omega R_L}$, so the maximum rate of build-up is proportional to $R(\omega)$.

Summing the rate of all the sine components in a step-wave to derive the maximum rate of build-up of the channel (since each component contributes equally to the maximum rate of build-up of the resultant response), the rate is given by

$$(8) \quad \frac{1}{\pi R_L} \int_0^\infty R(\omega) \, d\omega = \frac{1}{2 CR_L}$$

which is $\frac{1}{\pi R_L}$ times the channel energy spectrum itself and is independent of the shape of the spectrum envelope.

Thus, if the maximum rate is given by equation (8), then the minimum build-up time can be defined as

$$t_1 = 2 CR_L \quad (9),$$

which is simply the time interval between the intercepts on the steady-state levels of the applied step-wave by the projection of the tangent to the transition at the half-amplitude point. By so defining the minimum build-up time and the bandwidth (section b), an integral relationship involves from equations (4) and (9); that is

$$t_1 = \frac{\pi}{\omega_1} \quad (10)$$

While equation (10) may not describe satisfactorily the performance of a specific channel, it most certainly formalizes the optimum capabilities of the channel and therein lies its importance.

Part II, the completion of this article, will appear in Issue 6 of the Du Mont Instrument Journal.

3. Cherry, C., Pulses and Transients in Communications Circuits, pp 135
 4. Cherry, C., Pulses and Transients in Communications Circuits, pp 165

Who and Why

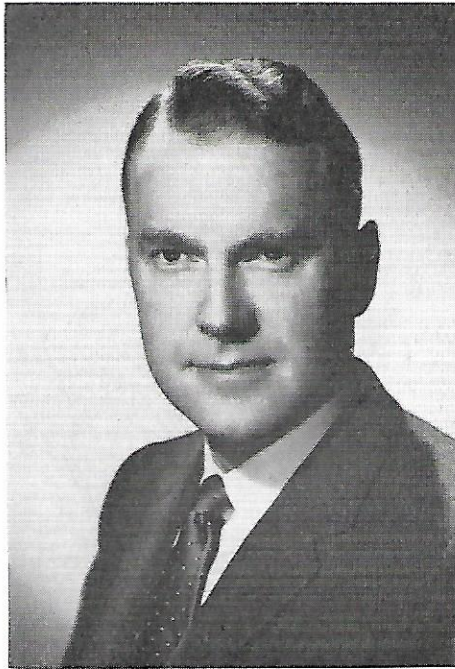

RUSH S. DRAKE

Rush S. Drake was born in Seattle, Washington on September 15, 1917. Rush grew up in the Seattle area, and upon graduation from High School, entered the University of Washington, majoring in electrical engineering. While at the University of Washington, Rush was a member of the Naval Reserve Officer Training Corps, and upon graduation he received both his BS Degree in electrical engineering and a commission as an Ensign in the Naval Reserve.

When he graduated from college he was elected to the Westinghouse Student Course in East Pittsburgh, Pennsylvania, which he joined in the fall of 1940. The stint with Westinghouse was interrupted by Uncle Sam, as on January 25, 1941 he was called to active duty in the Bureau of Ships. The following three and a half years in the Navy Department were extremely interesting for Rush because he was one of the first officers to report to the then—Radio Division—

and was in on the tremendous growth and expansion during World War II. In the spring of 1944, he was transferred to the Fleet Maintenance office of Comservpac and was directly concerned with the logistic control of all electronic equipment from the West Coast to the Pacific Area.

Following his discharge from the service, in the fall of 1945, and for the next five years, Rush left the engineering field and worked with his father in a General Insurance Agency in Seattle. During this time he had kept up his Naval Reserve activities and had also been very active as a radio amateur; W7ESK. With the outbreak of hostilities in Korea, he was again called to active duty in the Navy Department, Bureau of Ships, Contract Division, as technical assistant to the contracting officer for electronics.

After leaving the Navy in 1952, Rush joined Hoffman Laboratories of Los Angeles as their Eastern representative with headquarters in Washington, D. C. He held this job up to the time he decided to return to Seattle and start his own business as a manufacturers' representative. While in the Washington, D. C. area, he was able to keep up with his amateur activities, and was very active, particularly in DX contests as W4ESK. Having come from the West Coast, he was particularly pleased to achieve the top U. S. score in the ARRL phone DX contests in 1952 and 1953.

After returning to Seattle in August, 1954, he founded Rush S. Drake Associates, Inc. This business in Seattle has grown steadily and today the office consists of an additional engineer and two girls.

Rush is the proud father of three very active children, Rusty, aged 16; Bruce, 14; and Peggy, 11. With the fine facilities of the Pacific Northwest for skiing and boating, the family is

(Continued on page 11)

Preamplifier with High Common Mode Signal Rejection

By: William P. George, Senior Engineer
Du Mont Instrument Division

This article details a technical definition and derivation of common mode signal rejection—an often misused term in the field. The application of its principle in a commercially available transistorized preamplifier is discussed in theory and in practical terms.

The need for an instrument which minimizes the undesirable effects of a common mode signal (e.g. stray pickup, noise, etc.) arises in working with low level signals on a balanced system. It is not uncommon to have the effects of a common mode signal swamp out a small differential signal that is to be measured.

At this point, it would be helpful to understand what is meant by the term Common Mode Signal Rejection.

Common Mode Rejection¹, Definition

For years, the term "Common Mode Rejection" has been used by scientists and engineers, but unfortunately not all of them agree as to the usage and definition of the term.

There is an obvious need for a definition of this term that is agreed to by all. The following definition set forth is one that has been agreed to by engineers at Allen B. Du Mont Laboratories, Inc., Clifton, New Jersey.

Before going into the definition we must first define the terms that will be used therein.

Common Mode Signal:—A signal that is common to the two non-

grounded terminals of a balanced system. This signal being taken with respect to the third terminal of the balanced system, which is ground.

Differential Mode Signal:—A signal that is placed between the two non-ground terminals of a balanced system.

The common mode rejection of a system is a measure of the system's ability to minimize the conversion of a common mode signal applied at the input to a differential mode signal at the output. It is expressed as a ratio of differential gain to common mode conversion.

The terms used in the derivation are defined as follows:

e_d	= differential mode signal input
e_c	= common mode signal input
e_{od}	= differential mode signal output due to differential mode signal input
e_{oc}	= differential mode signal output due to common mode signal input
G_d	= differential gain
CMC	= common mode conversion

1. For reason of brevity, the term Common Mode Rejection is used in place of Common Mode Signal Rejection.

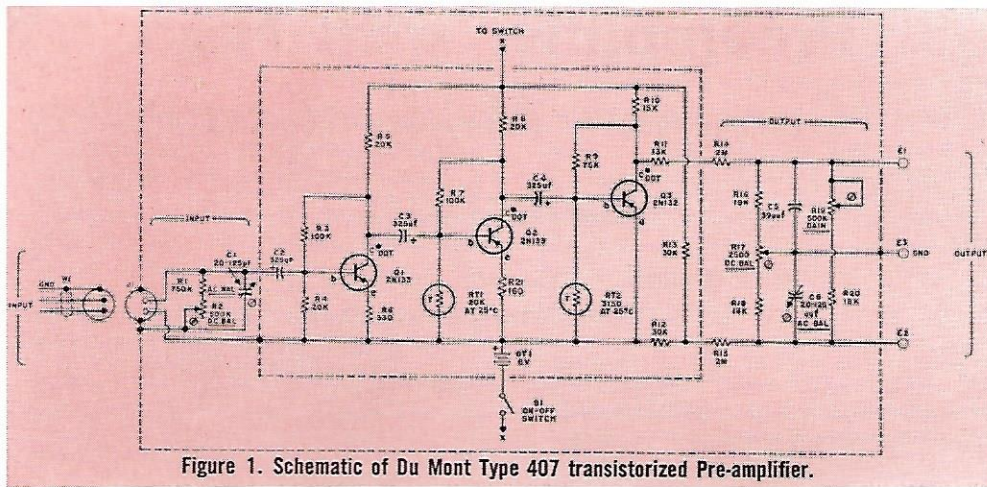

Figure 1. Schematic of Du Mont Type 407 transistorized Pre-amplifier.

CMC_{in} = common mode conversion referred to input
 CMR = common mode rejection

Derivation

Common Mode Conversion of a system

$$= CMC \triangleq \frac{e_{oc}}{e_c}$$

In order to make the common mode conversion independent of the differential gain of the system, it is referred to the input.

$$CMC_{in} = \frac{CMC}{G_d}$$

$$\text{where } G_d \triangleq \frac{e_{od}}{e_d}$$

$$\text{by definition CMR} \triangleq \frac{1}{CMC_{in}}$$

$$\text{therefore CMR} = \frac{G_d}{CMC}$$

There are various methods of obtaining a high common mode rejection. With the advent of transistors a new practical method was conceived. This new method gives additional sensitivity to differential input instruments and has the added feature of a very stable high common mode rejection, higher than was previously obtainable in commercially available units.

Theory

By operating a transistor amplifier on batteries, it is possible to float the

amplifier circuit ground and use it as one side of a balanced input. Thus, any common mode signal present at the input terminals (e.g. stray pick-up, noise, etc.) is passed through the amplifier, while any differential signal is amplified. At the output of the amplifier, both signals are passed through a *balanced* passive attenuator and attenuated.

The purpose of the balanced attenuator is to attenuate the common mode signal, thereby reducing the common mode signal at the input to the associated equipment. The balancing feature allows the user to minimize any conversion taking place (due to unbalance) in the attenuator and in associated equipment attached to its output. If this attenuator were perfectly balanced over a wide bandwidth there would be no conversion in it of common mode to differential signal. Perfect balance is very difficult to obtain over a broad bandwidth. A reasonably good balance may be obtained by the adjustments incorporated into the attenuator.

It should be noted (see Figure 1) that in the transistor preamplifier, unlike its vacuum tube counterparts, the common mode rejection does not depend upon any active elements (like tubes), but strictly on the passive characteristics of the attenuator; therefore, the common mode re-

Development

jection will not drift with aging of tubes as it does in the vacuum tube counterpart.

Conversion from common mode signal to differential signal may take place, due to impedance unbalance, in the output attenuator and associated equipment attached to its output, —also in the input and its associated source impedance. A difference of impedance between the two floating input leads of the amplifier would cause currents of different values to exist when a common mode signal is applied. This would cause a voltage difference at the input of the amplifier, hence conversion to differential signal.

The inclusion of input balance controls was found necessary in order to equalize the impedance seen looking into either input terminal of the floating amplifier. These controls can also adjust for some small unbalance in the source impedance. The input balance controls thus minimize any conversion taking place at the input.

Circuit Description

The differential signal input is first amplified by a factor of 1000 and then attenuated along with any common mode signal by 100, thus making the differential gain equal to 10. Since common mode signals on the input terminals are attenuated by 100 the differential to common mode signal ratio is improved by a factor of 1000. By minimizing the available common mode signal through a balanced attenuator, the common mode conversion was found to be in the order of 10^{-5} or better. This, therefore, makes the common mode rejection

$$\text{CMR} = \frac{\text{Differential Gain}}{\text{Common mode conversion}} = \frac{10}{10^{-5}} = 10^6$$

Application

If this instrument were placed before a differential input oscilloscope,

the sensitivity would be increased by 10. The common mode signal available on the input terminals of the scope (that could be converted to differential signal by the scope) would be reduced by 100. The conversion from common mode to differential signal in the input terminals of the scope would be minimized. It should be noted that the display on the cathode-ray tube of a scope is due only to differential signals applied to its deflection plates. Common mode signal can affect the display only if it is converted to a differential signal.

By slightly unbalancing the output controls of the preamplifier, it is possible to balance out some of the conversion taking place in the scope input.

The circuit design includes both A.C. and D.C. stabilization through feedback. The unit is temperature compensated with thermistors (operative range 0°C to 40°C .). The only maintenance required is battery replacement every 1000 hours.

Who and Why (cont.)

now busily engaged in pursuing these outdoor sports. Dad is having a tough time keeping up with his active youngsters.

Since starting his own business, the ham radio activity has taken a back seat, but for those who read this article, or who happen to have run into W4/W7ESK, we are pleased to report that a new transmitter is about completed and that Rush will be back chasing DX in the near future.

BINDERS

The staff of the Instrument Journal is interested in knowing how many of our readers would like to have a red vinyl plastic binder for subsequent issues of the Journal. A quick response would be appreciated. Complete Details are given on page 14.

Development

Accelerometers and Acceleration Measurement

The ever increasing speeds in transportation of personnel and equipment, the increasing complexities of missile navigation and instrumentation, and the corresponding need for greater reliability and ruggedness in machines have pressed industry to provide instrumentation for measurement of performance under increasingly severe environments. One cannot help observing that this has resulted in a greatly increased popularity of acceleration measurements. The reasons for the more extensive use of accelerometers are that these transducers provide convenient methods of determining stress factors, load levels, and shock and vibration transmission. Accurate measurements of these factors are demanded as power, speed and weight of mechanical devices increases.

Accelerometers are also being put to use in other fields such as medical physics. For example, in ballistic cardiography they may be attached to the patient or ballistic table to sense the reaction forces caused by the heart pump and blood flow.

Since oscilloscopes as well as VT-VM's, digital counters and other electronic instruments find increasing application in mechanical measurement, it becomes a continuous task for users and manufacturers of such equipment to be familiar with newer accelerometer characteristics (as well as all other transducers), and to keep up to date with improvements in their design and with the applications to which they are put. Du Mont's Instrument Applications Engineering Department also has to be familiar with types of displays, sensitivities, and frequency range characteristics, etc., of accelerometers and all other

transducers. Their concept goes a step beyond just helping to solve problems in applications of the Oscilloscope, they have to be able to use their knowledge of these applications to determine the limitations of present scope designs and to set the specifications for newer and more useful designs.

The following is a very brief review of types of accelerometers, compiled by the applications department, which has been gathered for their own use as well as an aide to Du Mont test equipment users.

Description of Accelerometers

The inter-relationships between acceleration, velocity and displacement are defined by Newton's Laws of Motion. Therefore, the output of a displacement pick-up may be differentiated to give velocity and double differentiated to measure acceleration. However, present day accelerometers provide an electrical output which is directly calibrated in "g", or acceleration. A modern accelerometer is a seismic device; that is, it consists of a spring and a mass which is subjected to the force to be measured. Since the force needed to accelerate the known mass in the accelerometer is determined by the spring constant, and $F=M(a)$, then a measurement of spring deflection is proportional to acceleration. The output of an accelerometer therefore is a signal corresponding to spring deflection. This output may be calibrated in units of force or acceleration in "g's". Many different types of accelerometers are available and the total number is increasing almost daily. The table following this article lists a number of basic types of accelerometers and

(Continued on page 14)

Comparison of Types of Accelerometers

TYPE	PRINCIPLE OF OPERATION	ACCELERATION RANGE IN G'S	APPROXIMATE FREQUENCY RANGE CPS	GENERAL CHARACTERISTICS
Piezoelectric	Piezoelectric crystal often used as spring. Distortion of crystal causes electrical charge between crystal faces.	0.1 to 50,000	2—20,000	Self-powered, high sensitivity, linear, usually requires preamplifier or cathode-follower, cannot be used for static displacement, high output impedance.
Strain Gage	Strain gage wire used as spring or it is bonded to spring. Stress changes resistance of wire in accordance with spring deflection.	0.1 to 1000	d-c to 1500	Requires external d-c or carrier frequency, low output impedance, low sensitivity; requires balanced bridge circuit linear.
Variable Reluctance	Ferromagnetic material part of seismic mass changes reluctance of air gap in a magnetic circuit. Sensed as a change in inductance of a coil.	0.1 to 1000	d-c to 500	Low output impedance, non-linear; requires an oscillator and demodulator system.
Differential Transformer	Slug of differential transformer is the seismic mass. Slug moves axially between two halves of secondary coil wound in opposition.	.01 to 750	d-c to 500	Linear, can easily be impedance matched; requires external carrier, balanced circuit and demodulator.
Tuned Wire	Wire connected to seismic mass is set into vibration by electro-magnetic means. Movement of mass causes load on wire changing its natural resonant frequency.		d-c to 20,000	Output is frequency modulated signal non-linear, requires special circuits.
Potentiometer	Movement of seismic mass causes movement of wiper contact.	0.1 to 70	d-c to 50	Requires very little external equipment, a-c or d-c supply required. Very low frequency response, limited resolution because of turns of resistance wire of pot.

NOTE: Acceleration and frequency ranges given apply for a number of units of each type rather than for any single transducer.

Accelerometers and Acceleration Measurements (continued)

briefly compares their characteristics and principle of operation.

The piezoelectric type of accelerometer is now probably one of the most widely used types because of its high-frequency response and its capability of handling a wide acceleration range. It is particularly applicable to investigations of shock phenomena. Its major drawback is its poor low-frequency response, requiring special networks to operate below 5 cps. It must be calibrated dynamically using sinusoidal vibrations of varying frequency.

Other types of accelerometers can be calibrated statically, using centrifuges to impose a steady state acceleration upon the instrument. Sometimes accelerometers are calibrated with shock devices such as drop and ballistic pendulums. Static calibration is fundamentally more accurate than dynamic calibration with the result that accelerometers capable of steady state acceleration measure-

ment are usually more accurate.

The potentiometer accelerometer may be considered as an opposite extreme and is limited to very low accelerations. It does, however, have high output capabilities. Its major drawback is that it imparts a certain amount of friction on a system and it has a resolution limited by the number of turns of resistance wire.

The strain gage accelerometer is popular because it can use a-c or d-c power and has adequate frequency response for a wide variety of problems. Under some conditions, its low sensitivity is a handicap.

Other types of accelerometers, such as the differential transformer and variable reluctance types, have important application but space does not permit a detailed description. Readers are invited to submit descriptions of acceleration measurement techniques, using oscilloscope displays, which they have used for publication in this journal.

References

1. "Transducers" — Carl Berkley, *Du Mont Oscillographer* Jan-March 1950
2. A. Orlacchio & G. Huber — "Accelerometers — Which Types for the Job", *Electronic Industries*, March 1957.
3. *Instructions for the Application of Piezoelectric Transducers* published by Endevco Corporation, Pasadena, California.

Vinyl Plastic D.I.J. Binders

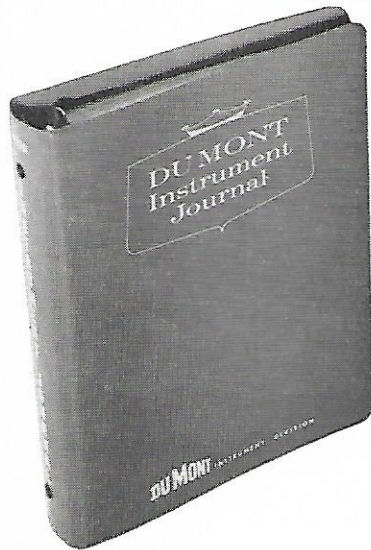

The picture comes as close to describing the appearance of the new *Du Mont Instrument Journal* binders as we can get. The vinyl plastic cover assures years of wear. The 1 1/4-inch three ring holder, with "push" lifters, also gives the backbone a sturdy, non-collapsible support. We experimented with average thickness issues of the *Du Mont Instrument Journal*, and found that the binder will hold at least a six year's supply comfortably.

Your check or money order for \$1.50, made out to Allen B. Du Mont Laboratories, Inc., will enable us to send you a binder postpaid. An attractive and useful addition to any technical literature library.

EDITOR'S PAGE

Tell Each Other

We've all been reading disturbing stories lately about our country being behind in technological developments and scientific advancement in general. Interviews, investigations, letters to editors, etc., all seem to be in agreement that we are lagging in some cases, but that this lag *could* have been avoided with better communications among military services and all technical people.

We all know that intercommunication is important. For something as important as the country's scientific advancement, collective intercommunication is vital. Suggestions by well known scientists have even advised a central information pool.

In a recent issue of the *Du Mont Instrument Journal* we introduced a new feature called "The Engineer Speaks". This page is for the sole purpose of publishing written con-

tributions from you technical people. A place for you to exchange ideas or to get something across that has been plaguing you. Perhaps you took note of the thought in the article presented in Issue 4 — an engineer wanted, if possible, to make a job easier for someone else.

We can't solve the entire intercommunication problem for all science in this country, but in our small way we are trying to help. We are not a subscribed-to publication, but we are a highly respected technical journal that is mailed to over 42,000 technical people in this country and throughout the world every three months—at their request and if they are technically qualified.

Send us your thoughts. You can probably make another technical person's job easier directly, and indirectly help solve the big intercommunication problem bothering the science world in general.

New Appointment

We are happy to welcome Mr. Leon Seldin as the new assistant sales manager of the Du Mont Instrument Division. A former Du Mont engineering section head, Leon returns to us after leaving in 1956 to join Federal Instruments, International Telephone and Telegraph Corp., as manufacturing manager.

Mr. Seldin became associated with Du Mont in 1948, and during his nine year stay he served as an engineer with the Television Receiver Division and the Instrument Division.

From 1946 to 1948, Leon was an instructor in the Electrical Engineering Department at the College of the City of New York.

A senior member of the IRE, Mr. Seldin received his master of science degree from Columbia University, and his bachelor degree in electrical engineering from the College of the City of New York. His recognized



Leon Seldin

technical prowess will be a great asset to the company in his relationship with users of Du Mont Test Equipment.

Fidelity of 404 push-button attenuation is shown in the multiple exposure of a 1 usec pulse. The db levels shown are 1/2, 1 1/2, 3 1/2, 5 1/2, 7 1/2 and 9 1/2

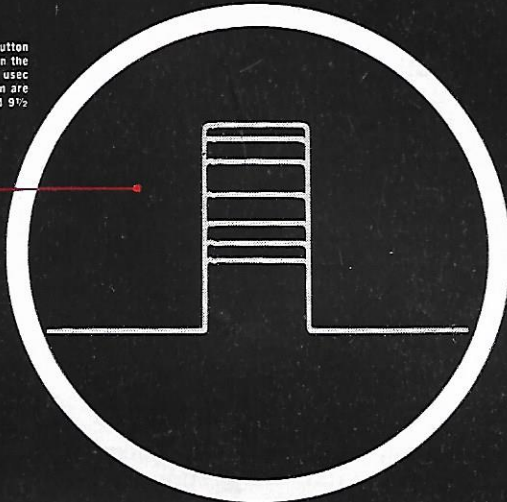

**0.018 usec
RISE TIME**

**100,000 pps
REP. RATE**

Du Mont



**Pulse
Generator**

- Repetition rates up to 100,000 pps, manual trigger for single pulse
- 0.018 usec maximum pulse rise and fall time
- Pulse width continuously adjustable from 0.05 to 100 usec
- 50 volts maximum output into 50 ohm impedance
- 59.5 db of attenuation in 0.5 db steps with no pulse degradation
- Hard tube circuitry eliminates jitter due to hydrogen thyratron erratic firing.

The Du Mont 404 Pulse Generator sets new standards for stability and versatility, outmoding pulse generators employing hydrogen thyratrons. The performance of the 404 reflects the entirely new "hard-tube" circuitry concept employed.

The capabilities of the 404 provide excellent facilities for ultra-high frequency studies at moderate cost. Its hair-line firing of sharp-edged pulses, push-button stepped attenuation, high rep rate, minimum jitter, easy-to-use front panel and control layout, internal delay from 2 usec before trigger to 100 usec after—all add up to a multiple use instrument that's good for years of dependable performance.

Price **\$675**

Rack-mounting model \$690



Write For Complete Technical Details...

DU MONT

SCIENTIFIC INSTRUMENT SALES DEPARTMENT, ALLEN B. DU MONT LABORATORIES, INC.

One of the 400 Series