

HICKOK

INSTRUCTION MANUAL
for

MODEL OSK-4
D.C. OSCILLOSCOPE

HICKOK

TEACHING
SYSTEMS INC.

545 Technology Square, Cambridge, Mass.
A Subsidiary of The Hickok Electrical Instrument Company

milliano

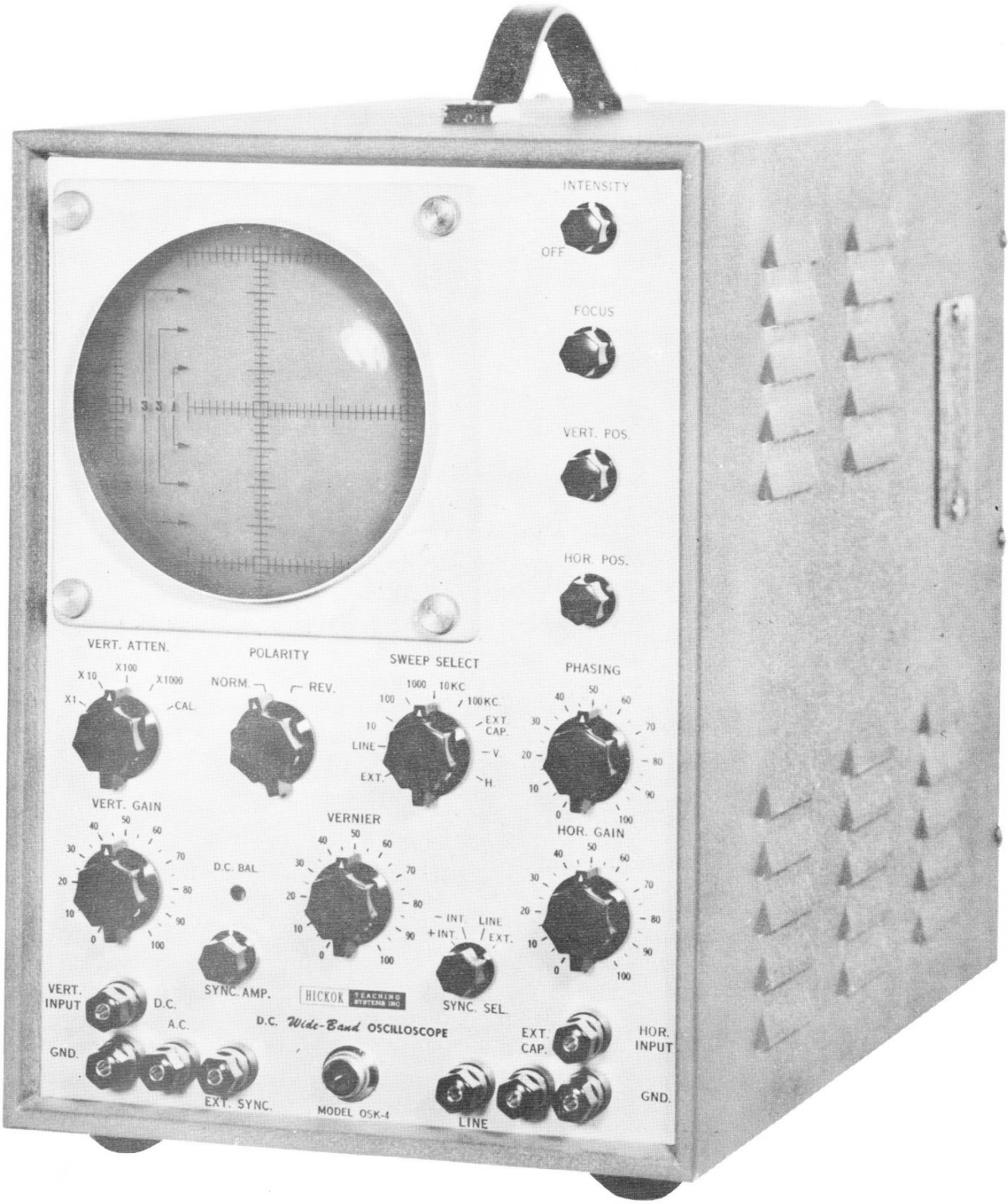

INTENSITY

OFF

FOCUS

VERT. POS.

HOR. POS.

VERT. ATTEN.

POLARITY

SWEEP SELECT

PHASING

X1 X10 X100 X1000 CAL

NORM. REV.

1000 10 KC 100 100 KC

40 50 60 70 80 90 100

VERT. GAIN

VERNIER

HOR. GAIN

30 40 50 60 70 80 90 100

D.C. BAL.

30 40 50 60 70 80 90 100

30 40 50 60 70 80 90 100

VERT. INPUT

D.C.

SYNC. AMP.

HICKOK TEACHING EQUIPMENT CO.

SYNC. SEL.

GND.

A.C.

D.C. Wide-Band OSCILLOSCOPE

EXT. CAP.

HOR. INPUT

EXT. SYNC.

MODEL OSK-4

LINE

GND.

TECHNICAL DATA SHEET

Vertical Channel - three stage, push-pull

Sensitivity - D. C. 70 millivolts/inch
A. C. 25 millivolts rms/inch

Frequency Response - (sine wave)
D. C. - Flat within 3 db from D. C. to 4.5 mc.
Flat within 5 db to 5 mc.
A. C. - Flat within 3 db from 10 cps to 4.5 mc.
Flat within 5 db at 5 mc.

Rise Time - less than .08 microseconds.

Overshoot - 5% or less

Input Impedance - 1.5 megohms shunted by 33 mmfd. maximum

Vertical Input Step Attenuator - frequency compensated

Vertical Polarity Reversal Switch for inverting screen pattern

Input Coupling - direct or capacitive

Input Characteristics - 600V peak RMS on the highest attenuator position

Horizontal Amplifier -

Sensitivity - .25 volts (RMS) per inch

Frequency Response - flat within \pm 3 db from 5 cps to 350 kc.

Input Impedance - 4.7 megohm shunted by 30 mmfd.

Gain - gain control of the cathode follower type

Input Characteristics - Selector switch allows the use of an external signal through a panel terminal, of the internal line frequency phase controlled signal, or of the internal sweep signal. Provision is also made for the use of an external capacitor to control the sweep frequency.

Positioning - push-pull type permits a wide range of positioning necessary to examine any part of the trace even with full horizontal gain.

Sweep Generator -

- a) Range from 10 cps. to 100 kc. variable in four steps
- b) Two preset sweep frequencies are included in the circuit
- c) Provision on switch for use of external capacitor in sweep circuit

TECHNICAL DATA SHEET

Synchronization -

Internal positive or negative locking signal, self-limiting circuit.
Provision made for external variable sync. input

Retrace Blanking -

Positive retrace blanking regardless of sweep frequency

Other Features -

Calibration Voltage - Built in and regulated, 60 cps. semi-rectangular waveform,
200 millivolts Peak to Peak

Phasing Control - 60 cps. operating on line sweep

D.C. balance adjustable from front panel

Astigmatism adjustable at rear of cabinet

Direct connections to deflection plates via removable door on side of cabinet

Power Supply -

A.C. supply only 117V/50-60 cycles

Fused for 2 amperes

High voltage 1300 volts, CRT supply

Low voltage 400 volts

Filament voltage 6.3 volts, A.C.

The OSK-4 is a wide band oscilloscope of high sensitivity equally useful in A.C. or D.C. applications. Some of the features are listed below:

-Highly stable trace

-Special alloy CR tube shield minimizes trace distortion due to external magnetic fields

-Astigmatism control is provided to assure a sharp trace

-Choice of direct or capacitive input coupling.

-Instantaneous drift-free positioning.

-Intensity modulation input

-Direct connection to cathode ray tube easily accessible through removeable side panel.

-Two switch selected preset sweep frequency positions provided for repeatedly used frequencies.

-Power supply fused for protection. Fuse accessible without removing cabinet.

Dimensions - 9-1/2" wide x 13-1/8" high, 18" deep

Weight - 30 lbs.

SECTION I - DESCRIPTION

1. PURPOSE:

The STARK OSK-4 is a general purpose oscilloscope designed to meet the needs of Radio and Television Industries and to allow complete visual analysis of electrical and electronic circuits. It is designed to accurately portray sinusoidal waveforms, non-sinusoidal waves of special shapes such as square waves, etc., within the amplifier limitations. By direct application to the Cathode Ray Tube plates, waveforms with characteristics which exceed the amplifier limits may be viewed.

The STARK Model OSK-4 weighs approximately 30 pounds and is housed in a wrinkle finish steel case. The panel is of a satin finish aluminum with markings permanently etched. All controls are located on the front of the panel and clearly marked as to their function. At the side of the cabinet, under a covering plate is located a terminal strip which allows for the connecting of a signal directly to the deflection plates of the Cathode Ray Tube. An auxiliary spot-shape control is accessible through a hole at the rear of the cabinet.

SECTION II - THEORY

1. GENERAL:

The cathode ray oscilloscope is an instrument for plotting a visual curve of one electrical quantity as a function of another electrical quantity. The resultant curve is displayed on the fluorescent screen of the cathode ray tube. The cathode ray tube consists of the following: an electron gun assembly which generates the electron beam, a means of focusing the electron beam into a sharp spot, and a means of deflecting the electron beam both horizontally and vertically.

Figure 2. shows the general construction of a cathode ray tube. The electron beam is generated by the cathode, controlled by the grid potential, focused by the first anode, accelerated by the second anode and controlled in position by the potential placed on the vertical and horizontal deflection plates. The trace is visible due to the effect of the electron beam on the fluorescent screen. The purpose of the aquadag (colloidal graphite) coating is to further accelerate the electrons and to provide a means for the return of stray electrons due to secondary emission.

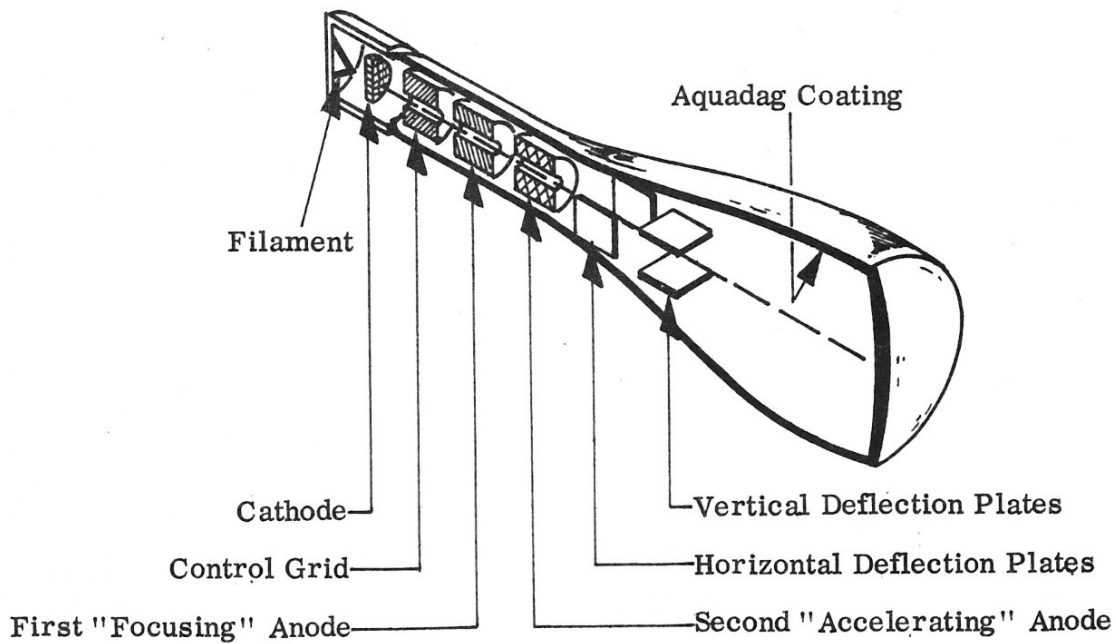

Figure 2. CATHODE RAY TUBE

In oscilloscopes such as the OSK-4 which are used for testing electronic equipment the voltage to be observed is applied to the cathode ray tube in such a manner as to deflect the beam vertically. The horizontal deflection is arranged so that the spot moves from left to right across the screen at a constant rate of speed and then rapidly returns to the left and repeats this action. If the repetition frequency of the linear sweep is equal, or is an integral sub-multiple of the frequency of the vertical deflection voltage, a stationary pattern appears on the screen of the cathode ray tube; this pattern is the vertical deflection voltage plotted against time. The ratio of the frequency of the vertical deflection voltage to the frequency of the sweep voltage determines the number of cycles which appear on the screen.

If the amplitude of the signal to be observed is small, it is necessary to include amplifiers in the oscilloscope circuit to increase the amplitude to a usable value. Also included in the oscilloscope circuit are means for focusing the spot on the screen, positioning the image on the screen, and synchronizing the linear sweep with the voltage to be observed.

2. CONSTRUCTION:

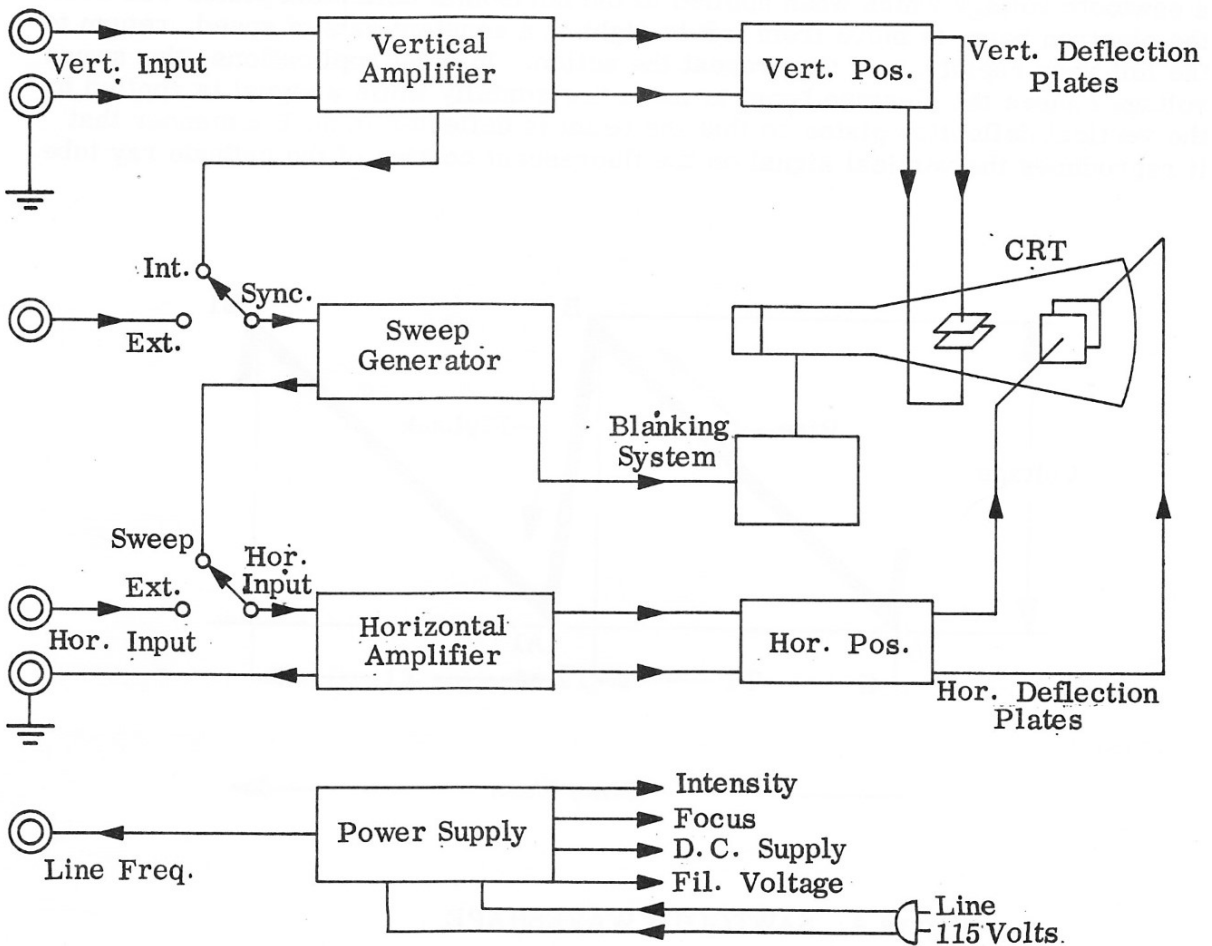

Figure 3. SIMPLIFIED BLOCK DIAGRAM
OSK-4 OSCILLOSCOPE

Line
115 Volts.
50/60 cps

3. THE VERTICAL AND HORIZONTAL AMPLIFIERS:

In order that an oscilloscope may have a wide range of use, it is desirable that an amplifier circuit be provided for the observation of small amplitude signals. Such an amplifier must accurately reproduce the shape of the waveform applied, it must have a uniform phase shift and uniform gain for all frequencies over a wide band. The frequency response of the OSK-4 vertical amplifier is flat within 5.0 db to 5 mc. The vertical amplifier will faithfully reproduce complex waveforms that contain many harmonics. The horizontal amplifier has a sufficiently wide band width so as not to distort the output of the sweep generator. It is capable of passing a sawtooth voltage in order to get a linearly changing voltage on the horizontal deflection plates. This characteristic is very important during the flyback time of the sawtooth since it is of extremely short duration.

4. THE SWEEP GENERATOR CIRCUIT:

The function of the sweep generator circuit is to move the electron beam in a steady continuous stroke across the screen so as to establish a reference of time. The waveform is referred to as sweep waveform while the circuit which produced the waveform is called a sweep generator. The output of this sweep generator is a sawtooth voltage which when applied to the horizontal deflection plates will cause the electron beam to move from left to right at a constant rate of speed, return to the left very rapidly, and then repeat the action. In most applications, the sweep voltage causes the electron beam to move horizontally while a signal is applied to the vertical deflection plates so that the beam is deflected in such a manner that it reproduces the vertical signal on the fluorescent coating of the cathode ray tube.

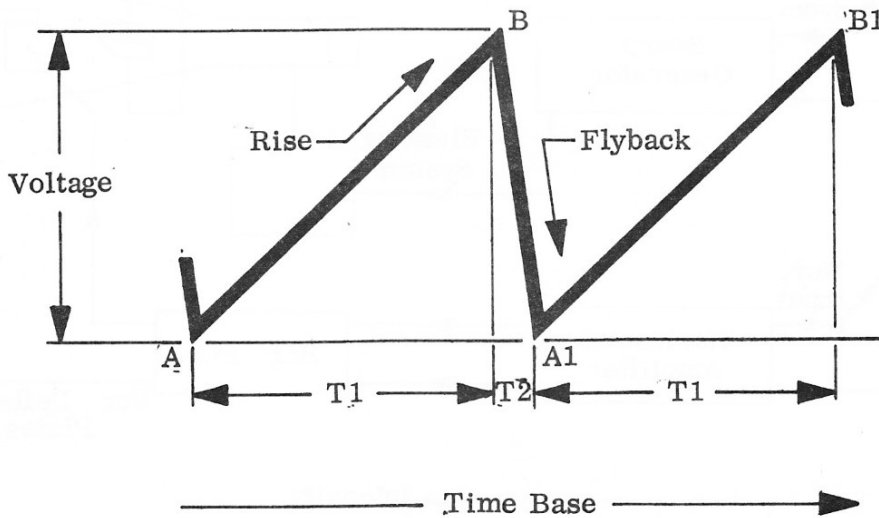

Figure 4. SAWTOOTH WAVESHAP

Figure 4. illustrates the sawtooth voltage that is used for the sweep by applying it to the horizontal deflection plates. The voltage is made to rise from point (A) along a straight line to point (B). This is known as a linear rise. If this voltage is applied to the horizontal deflection plates, the electron beam will move as desired, i. e. from left to right. In order to return the beam to the left again, this voltage must drop down to the value it had at point (A). Time T1 is called the rise time while T2 is called the flyback time, since it represents the time during which the beam is being moved back to the starting point. The return trace is blanked out by means of a blanking amplifier so this portion of the trace is not visible on the screen. The simplest way of obtaining the gradual rise in voltage followed by a sudden drop is by charging and discharging a condenser. This is generally accomplished by means of a relaxation oscillator.

5. BASIC MULTIVIBRATOR CIRCUIT:

Figure 5. shows the basic circuit of a relaxation oscillator of the common cathode feedback multivibrator type. This is one type of oscillator circuit used in oscilloscopes. The sawtooth voltage which is applied to the horizontal amplifier is developed by the slow charging of the plate capacitor C2. The charge is built up as the electrons flow into the lower plate of the capacitor while they flow away from the top plate through the relatively high resistor R2 and to B+. Because the resistor R2 and the capacitor C2 are variable the time of charging is variable. This produces the long sloping part of the sawtooth wave (A-B). However, the moment V2 starts to conduct, capacitor C2 is rapidly discharged through this tube. Thus the sudden drop in the waveform is brought about. As soon as the tube ceases conduction, the slow charge part of the cycle begins again. During the charging interval, tube V2 must be held at cut-off, and this is accomplished by the action of triode section V1. As the multivibrator oscillates due to the transfer of energy from section V1 to V2 and back to V1, the grid of V2 is driven momentarily positive. This causes grid current in V2, which quickly charges C1. As this capacitor slowly discharges through R1 to ground, the voltage so produced holds tube V2 at cut-off so that C2 will have a long interval in which to charge. When the resistance to ground of R1 and the capacitor C1 is reduced or increased by varying the position of the sweep selector or vernier control, the blocking bias of V2 will decay more or less rapidly. This in turn will cause the tube to conduct sooner or later, discharging C2 and varying the rate of sawtooth cycle. The incoming vertical synchronizing signal will take hold of the multivibrator circuit and keep the frequencies timed with those of the vertical amplifier.