

PORTABLE TUNING SCOPE Model PT-3

Operation Manual

SINCE 1887



YAMAHA



The Yamaha Tuning Scope Model PT-3 is a portable, easy-to-use instrument whereby you can ascertain with your eyes the correct tuning of a musical instrument. With this unit, tuning accuracy can be verified at a glance, for any type of instrument.

Please read this manual carefully, to make full use of the revolutionary precision and convenience the tuning scope affords, and to avoid abusing its power.

With proper care, model PT-3 will afford long years of durable, dependable service for precision tuning.

PARTS and CONTROLS

Fig. 1

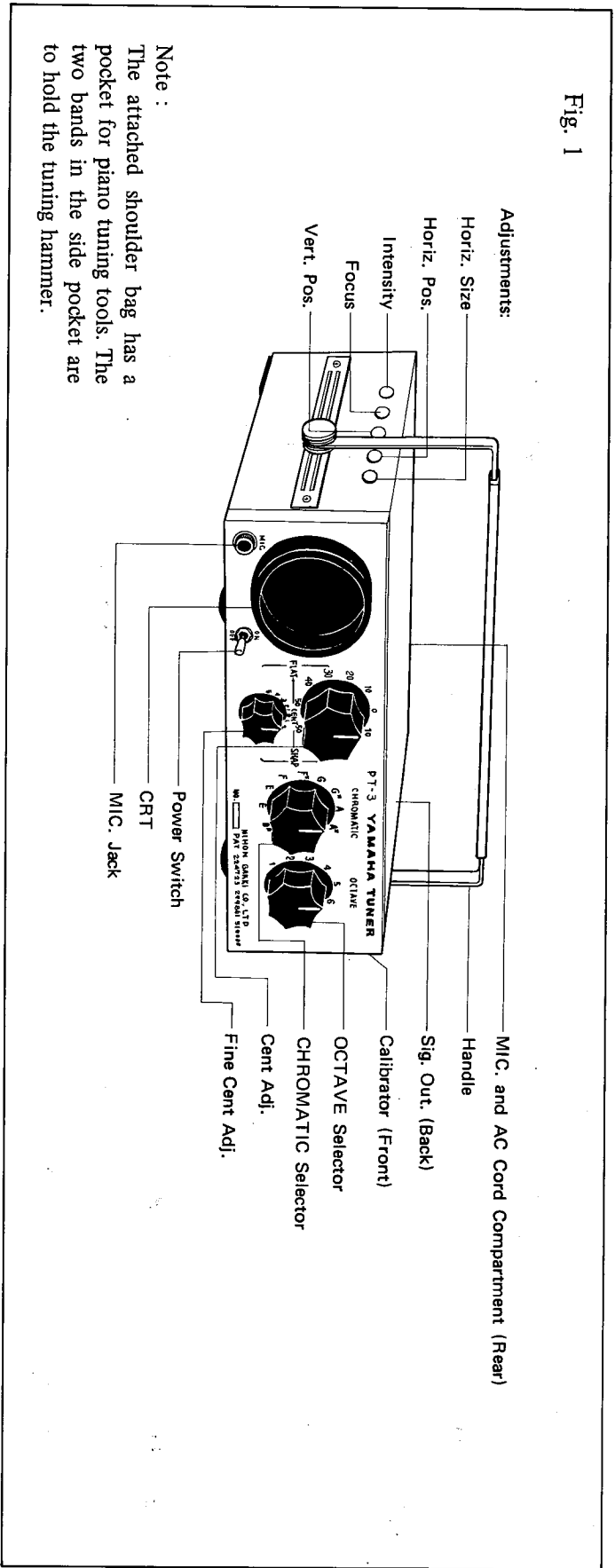

Note :
The attached shoulder bag has a pocket for piano tuning tools. The two bands in the side pocket are to hold the tuning hammer.

PREPARATION

1. Remove the unit from the bag by grasping the handle; place it by the musical instrument. The handle can be used as a stand by pulling it down under the unit; if this makes the scope too high to read comfortably, leave the handle up and use the rubber feet as the stand.
2. Remove the power cord from the Mic. and AC cord compartment, and plug it into an electric outlet.
3. Remove the microphone from this compartment and plug it into the MIC jack. Then place it in a position to pick up sounds from the instrument to be tuned.
4. Turn on the power switch. After a few seconds a green pattern approximately 10mm wide will appear across the Cathode Ray Tube (CRT).

OPERATION

1. PIANOS

Since harmonic overtones are not simple multiples of integral frequencies, the OCTAVE and CHROMATIC selectors and CENT adjusters must be set for each note.

- 1) Match the CHROMATIC selector setting to the key to be tuned.
- 2) Find the OCTAVE selector and CENT adjuster settings by referring to the Standard Piano Tuning Table (p. 13). The cent must be set by balancing the two selector settings. This can be seen by considering the settings when tuning the third key from the left (i.e., the lowest B):
First set the OCTAVE selector to 3 and the CHROMATIC selector to B. Then set for -18 by turning the CENT adjuster to 20 on the FLAT side and the fine CENT

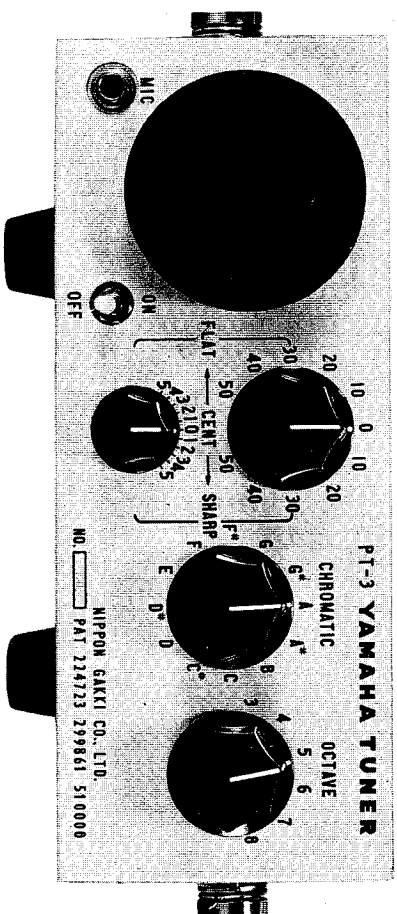

adjuster to 2 on the SHARP side. In other words, (-) corresponds to "flat" and (+) to "sharp "

- 3) Strike only one string for each note (stop the others with a mute), and tune so that the striped pattern stops moving.
- 4) Tune the other strings by ear, so that all beats are eliminated.
- 5) If you glance at the tuning standard table, you will see that some notes in the same octave have the same CENT. In such a case it is better to differentiate by tuning the higher notes above the setting (i.e., so that the striped pattern moves slightly to the right), instead of tuning the lower ones below it.

- 6) In the 8th octave it is sometimes difficult to ascertain in which direction the pattern is moving if there is a large difference between the string's frequency and the CENT setting of the tuning scope. In this case, move the adjusters back and forth to find which direction the pattern is moving. Be sure to reset the adjusters to their correct positions before tuning the string. Repeat the adjustment two or three times to be sure there is no mistake in the direction.

Note:

Pattern movement to the left means the note is flat, to the right, sharp. Always tune to stop such movement.

2. ORGANS and OTHER INSTRUMENTS

- 1) Set the CENT adjusters to zero.
- 2) Set the CHROMATIC selector to the note you wish to tune.

- 3) Sound the note and tune so that the striped pattern stops. The OCTAVE selector can be turned to any setting whereby pattern movement is clearly visible; in other words, the lower ranges require lower OCTAVE selector settings, and vice versa.

Note:

When tuning an electronic instrument, the signal can be fed directly to the tuning scope without using the microphone. Plug the signal cord (signal: app. 10mV) into the MIC jack via a coupling condenser.

MEASUREMENTS

Using model PT-3 it is also possible to measure exactly how far an instrument is out of tune. This operation is essentially the opposite of that used in tuning.

Set the OCTAVE and CHROMATIC selectors to the note to be measured. Then sound that note on the instrument and adjust the CENT adjuster and fine CENT adjuster until pattern motion stops. The CENT adjuster setting at that time shows the exact extent to which the instrument is out of tune on an a=440 Hz equally tempered scale. If the pattern does not stop moving within an adjustment range of ± 55 cents, the note is more than one-half semi-tone off key. In this case measurement can be continued by first adjusting the CHROMATIC selector, then turning the CENT adjusters fully back. For example, if an A tone is more than 55 cents flat, turn the CHROMATIC selector to G \sharp , set the CENT adjusters to +55, and continue measuring.

CALIBRATION METHOD

In order to calibrate the PT-3 Portable Tuning Scope, use either a frequency measuring instrument with a range of at least 880 to 1700 Hz, more accurate than $\pm 5 \times 10^{-5}$, or a tone or electric signal generator with the same rated accuracy. The former can be an electronic counter with a crystal-controlled standard frequency, the latter a standard tuning fork, or a crystal-controlled audio frequency standard instrument. With the frequency measuring instrument, connect the Sig. Out jack of the PT-3, located on the right side of the case (see Fig. 1), to the input terminal of the measuring instrument, (input impedance must be over 50K Ω). Then adjust the PT-3 calibrator so that the signal matches its rated setting.

Note:

When using a signal or tone generator, feed it to the MIC jack (directly or through the microphone), set the PT-3 selectors and adjusters to that tone and adjust the calibrator while watching the CRT.

PRECAUTIONS

1. Although the PT-3 is not affected by ordinary vibrations, such as when it is carried in a vehicle, be careful not to knock or drop it.
2. Do not place heavy objects on the unit, even when it is in its bag.

MAINTENANCE

1. The unit is factory adjusted for a clear pattern, but if this fades and loses its focus after some use, correct it with the Intensity and Focus adjusters.
2. If the Intensity adjuster is set too far to the right, the extreme brightness will eventually burn out the CRT. Therefore, do not set for more brightness than is necessary. Be sure to turn off the power switch when the tuner is not in use.

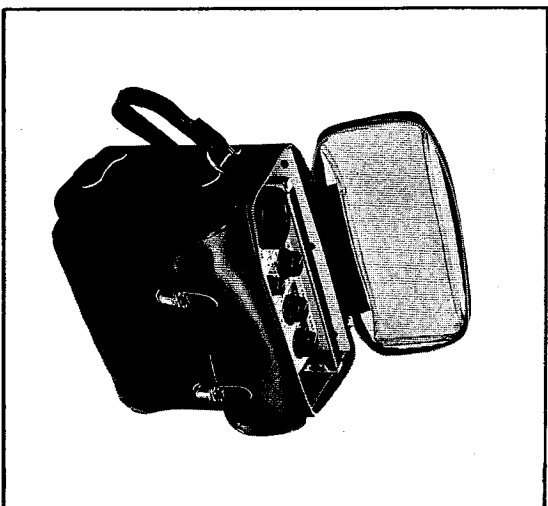

3. The size, horizontal and vertical positions of the striped pattern can be adjusted using the "Horiz. Size", "Horiz. Pos." and "Vert. Pos." adjusters, located on the left side of the case.
4. To remove the chassis, first take off the two screws from the bottom, then pull the chassis loose from each corner of the front panel. Do not pry the four chassis corners with a screwdriver or other tool.
5. Do not tamper with the Calibrator except when it is necessary to adjust the calibration. Unnecessary turning may throw the standard frequency out of order.

SPECIFICATIONS OF MODEL PT-3

Dimensions (W x H x D) :	23 (9") x 11 (4 1/4") x 19 (7 1/4"), including all protrusions except handle
Net weight :	3.75kg (8.5 lbs.) excluding bag
Tubes :	50HB1 (Dia. 5cm) x 1 6AV6 x 1
Transistors :	18
Power Source :	100, 110, 115, 125, 220 or 240V, 50-60Hz (preset)
Power Consumption :	10W ($\pm 10\%$ rated voltage)
Operative temp. range :	-10° to +40° C
Relative error of standard frequency :	± 1 CENT under rated voltage and temp. (1 CENT = 1/100 semi-tone)
Variable range of standard frequency :	- 55 to + 55 CENT
Measurable note range :	A (27.5c/s) to g (6,645c/s)
Accessories :	Shoulder bag x 1 Spare Fuses x 2 Microphone x 1

TROUBLE SHOOTING CHART

Trouble	Cause or Check Point	Remedy
No pattern on CRT (no spot)	Blown fuse	Replace
	Terminal voltage of C ₄₃ , C ₄₄ and CRT socket not normal	Replace Os and Rs
	CRT heater not lit	Replace CRT
	Above all normal	Replace CRT
	Microphone defective	Replace
Sound fed to microphone but pattern unaffected	Poor contact in MIC. or MIC. jacks	Adjust or replace the contact spring
	Tr ₁₂ - Tr ₁₇ and their circuits on circuit board YT-2C	Replace defective parts
	Tr ₁₁ , Tr ₂ and their circuits on C.B. YT-1C or Tr ₉ - Tr ₁₁ and their circuits on C.B. YT-2C	Replace defective parts
CRT not swept horizontally*	Tr ₃ - Tr ₈ (Freq. Divider) defective	Replace defective parts
	Poor contact on wafer #2 or #3 of OCT. selector sw.	Replace defective parts

* It is only necessary to check those circuits which correspond to Octave or Chromatic selector settings providing defective operation.

BLOCK DIAGRAM OF MODEL PT-3

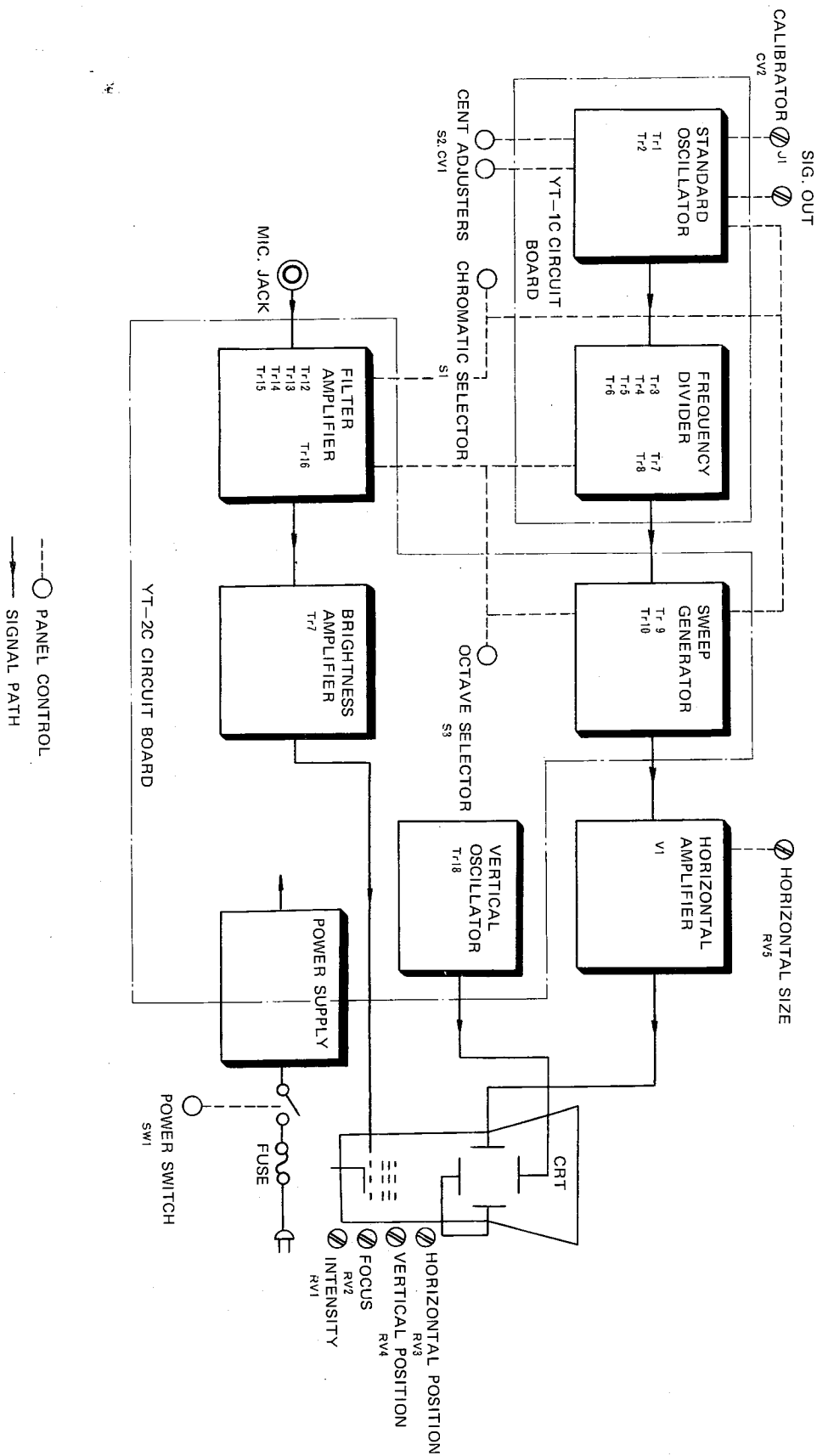

CIRCUIT BOARD YT-2C

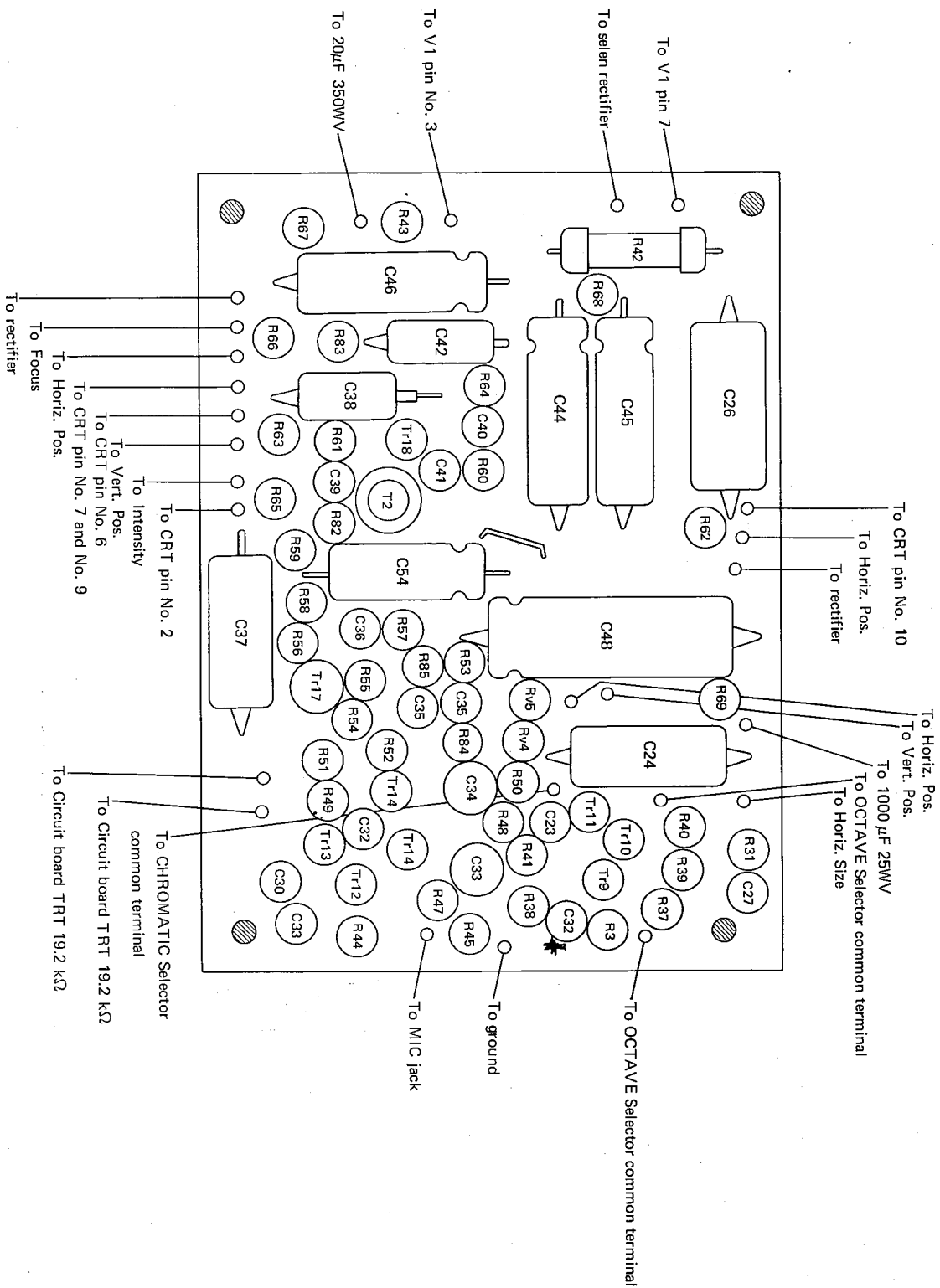

CIRCUIT BOARD YT-1C

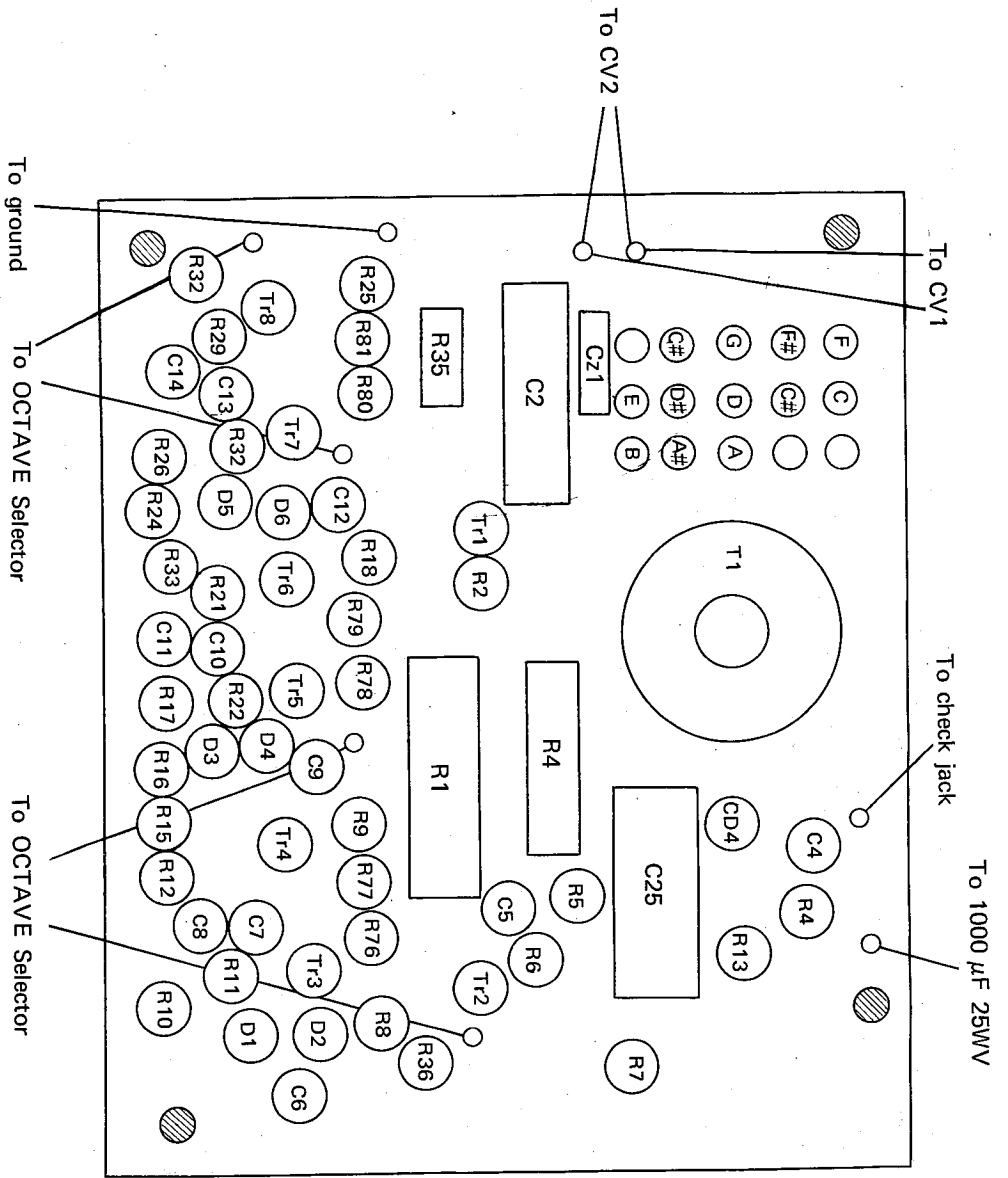

CIRCUIT BOARD T.T.R.

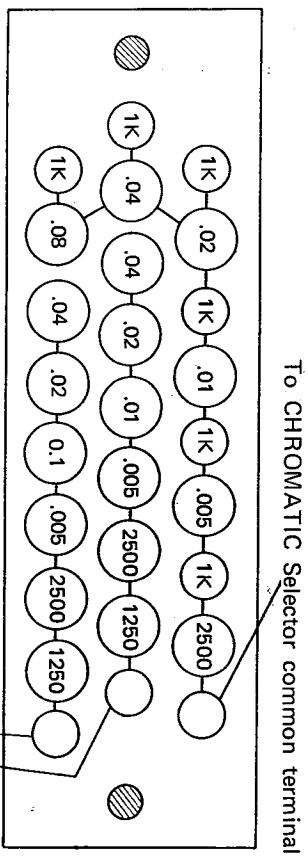

CIRCUIT BOARD T.T.C.

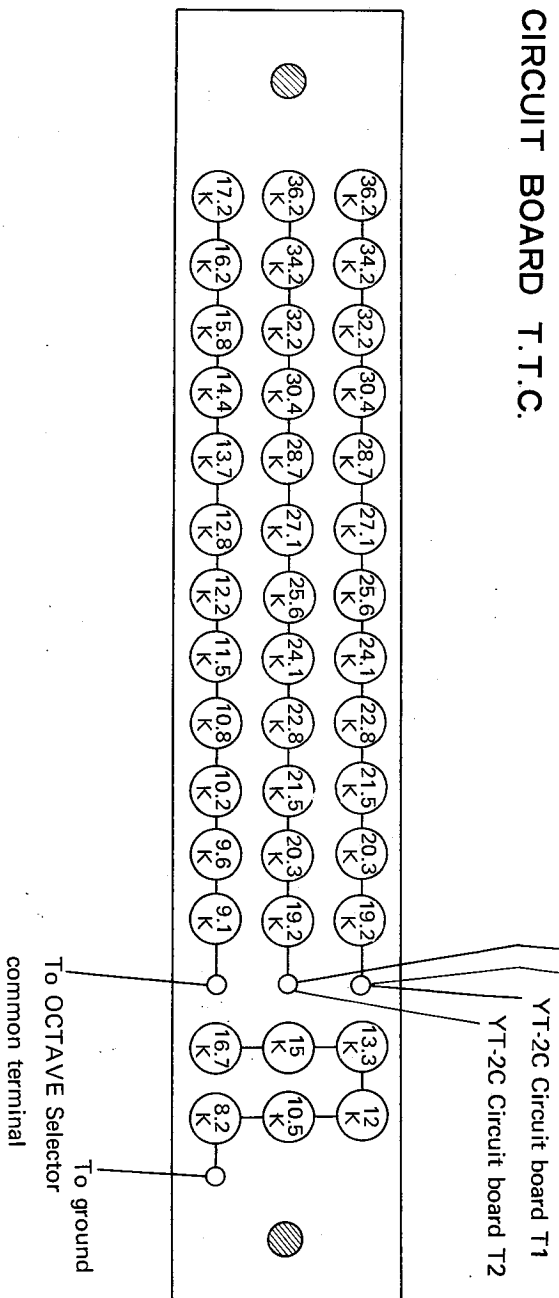

STANDARD PIANO TUNING TABLE

OCTAVE SELECTOR	KEY NO.	CHRO-MATIC	OFF SET (CENT)	OCTAVE SELECTOR	KEY NO.	CHRO-MATIC	OFF SET (CENT)	OCTAVE SELECTOR	KEY NO.	CHRO-MATIC	OFF SET (CENT)	OCTAVE SELECTOR	KEY NO.	CHRO-MATIC	OFF SET (CENT)	OCTAVE SELECTOR	KEY NO.	CHRO-MATIC	OFF SET (CENT)			
3	1	A	-20	4	25	A	3	5	49	A	0	7	73	A	6	8	77	C#	10			
	2	A#	-19		26	A#	3		50	A#	0		74	A#	7		74	A#	7	75	B	8
	3	B	-18		27	B	3		51	B	0		51	B	8		75	B	8	76	C	9
	4	C	-17		28	C	3		52	C	0		52	C	9		76	C	9	77	C#	10
	5	C#	-16		29	C#	3		53	C#	0		53	C#	10		77	C#	10	78	D	11
	6	D	-15		30	D	3		54	D	0		54	D	11		78	D	11	79	D#	12
	7	D#	-14		31	D#	3		55	D#	1		55	D#	12		79	D#	12	80	E	13
	8	E	-13		32	E	3		56	E	1		56	E	13		80	E	13	81	F	15
	9	F	-12		33	F	3		57	F	1		57	F	15		81	F	15	82	F#	17
	10	F#	-11		34	F#	3		58	F#	1		58	F#	17		82	F#	17	83	G	19
	11	G	-10		35	G	2.5		59	G	1		59	G	19		83	G	19	84	G#	21
	12	G#	-9		36	G#	2		60	G#	2		60	G#	21		84	G#	21	85	A	23
4	13	A	8	4	37	A	2	6	61	A	2	8	85	A	23	8	86	A#	25			
	14	A#	7		38	A#	2		62	A#	2		86	A#	25		87	B	27			
	15	B	6		39	B	2		63	B	2		87	B	27		88	C	30			
	16	C	6		40	C	2		64	C	2		64	C	30							
	17	C#	5		41	C#	2		65	C#	3		65	C#	30							
	18	D	5		42	D	2		66	D	3		66	D	30							
	19	D#	4		43	D#	1.5		67	D#	3		67	D#	30							
	20	E	4		44	E	1		68	E	4		68	E	30							
	21	F	4		45	F	1		69	F	4		69	F	30							
	22	F#	4		46	F#	1		70	F#	5		70	F#	30							
	23	G	4		47	G	1		71	G	5		71	G	30							
	24	G#	3		48	G#	1		72	G#	6		72	G#	30							



YAMAHA

Nippon Gakki Co., Ltd. P.O. Box 1, Hamamatsu, Japan

1000 1000

PS-10

7011⊗ Printed in Japan