

## REPLACEMENT PARTS

Insist on genuine factory-tested parts, which are readily identified and may be purchased from authorized dealers.

STOCK No.	DESCRIPTION	STOCK No.	DESCRIPTION
33873	Cable—Input cable complete	32059	Holder—Tubular type fuse holder with screw cap
12814	Capacitor—5.6 mmfd. (C1, C18, C22, C26)	30925	Handle—Carrying handle for case
14079	Capacitor—6.8 mmfd. (C19, C21)	47061	Jack—Black binding jack (J1, J4)
13001	Capacitor—8.2 mmfd. (C25)	47228	Jack—Red binding jack (J2, J3)
12948	Capacitor—33 mmfd. (C15)	32116	Knob—Control knob
12813	Capacitor—82 mmfd. (C23)	47062	Post—Binding post (use with 47061 and 47228)
13894	Capacitor—390 mmfd. (C7)	13428	Resistor—150 ohms, 1/4 watt (R35)
12537	Capacitor—560 mmfd. (C17)	30546	Resistor—470 ohms, 1/4 watt (R5)
13054	Capacitor—1,200 mmfd. (C8)	12414	Resistor—560 ohms, 1/4 watt (R34)
4881	Capacitor—3,300 mmfd. (C3, C35)	14076	Resistor—820 ohms, 1/4 watt (R27)
30856	Capacitor—.015 mfd. (C10)	14720	Resistor—1,000 ohms, 1/4 watt (R3)
30857	Capacitor—.035 mfd. (C11)	12267	Resistor—1,200 ohms, 1/4 watt (R49)
30848	Capacitor—.01 mfd. (C12)	6134	Resistor—1,200 ohms, 1 watt (R10)
18000	Capacitor—.01 mfd., 1,250 volts (C42, C45, C48, C50)	13716	Resistor—2,200 ohms, 1/4 watt (R32)
30849	Capacitor—.025 mfd. (C4, C14, C36)	13714	Resistor—5,600 ohms, 1/4 watt (R30)
30860	Capacitor—.05 mfd. (C16, C40, C41, C53)	14559	Resistor—10,000 ohms, 1/4 watt (R7, R17, R20)
18416	Capacitor—1 mfd. (C2, C13, C29, C30, C31, C32)	3219	Resistor—18,000 ohms, 1/2 watt (R48)
33879	Capacitor—10 mfd., 300 volts (C38, C39, C44, C47)	33862	Resistor—18,000 ohms, 20 watt (R37)
33880	Capacitor—10 mfd., 300 volts, 10 mfd., 300 volts, 10 mfd., 150 volts, 20 mfd., 25 volts (C43, C46, C49, C51)	30409	Resistor—27,000 ohms, 1/2 watt (R11)
33865	Capacitor—10 mfd., 450 volts, 10 mfd., 450 volts, 40 mfd., 25 volts (C5, C33, C34)	14167	Resistor—27,000 ohms, 2 watt (R47)
33159	Capacitor—250 mfd., 15 volts, 10 mfd., 350 volts, 10 mfd., 150 volts (C28, C37, C52)	12454	Resistor—33,000 ohms, 1/4 watt (R31)
12477	Choke—Filter reactor (L4)	12487	Resistor—33,000 ohms, 2 watt (R46)
33881	Choke—Horizontal amplifier plate choke (L1)	6143	Resistor—43,000 ohms, 1/4 watt (R22)
33867	Choke—Vertical amplifier plate choke (L2, L3)	14560	Resistor—100,000 ohms, 1/4 watt (R8, R19)
11859	Condenser—3 to 30 mmfd., variable condenser (C27)	3252	Resistor—100,000 ohms, 1/2 watt (R28, R39)
33866	Condenser—60 to 120 mmfd., variable condenser (C20, C24)	30154	Resistor—100,000 ohms, 1 watt (R4)
33870	Connector—Input cable connector (J5)	13483	Resistor—120,000 ohms, 1 watt (R36, R38)
33874	Control—1,000 ohms—synchronizing control (R6)	11676	Resistor—200,000 ohms, 1/4 watt (R24)
17694	Control—10,000 ohms—low frequency compensating control (R29)	14583	Resistor—220,000 ohms, 1/2 watt (R42)
33861	Control—10,000 ohms—vertical gain control (R33)	30784	Resistor—330,000 ohms, 1/2 watt (R14, R50)
13984	Control—50,000 ohms—compensating control (R18)	12285	Resistor—470,000 ohms, 1/4 watt (R13, R40)
33863	Control—50,000 ohms—intensity control and power switch (R41, S2)	36243	Resistor—470,000 ohms, 1 watt (R44, R45)
33864	Control—250,000 ohms—focus control (R43)	30963	Resistor—820,000 ohms, 1/4 watt (R25)
33859	Control—500,000 ohms—horizontal gain control or centering control (R2, R51, R52)	13730	Resistor—1 meg., 1/4 watt (R23, R26)
33860	Control—2 meg.—frequency control (Fine) (R12)	30652	Resistor—1 meg., 1/2 watt (R1, R21)
33872	Escutcheon—Front panel escutcheon	12201	Resistor—1.5 meg., 1/4 watt (R15, R16)
30926	Foot—Elastic foot for case	33871	Screen—Calibration screen for cathode-ray tube
14133	Fuse—1 ampere line fuse (F1)	31769	Socket—4-contact tube socket (V6, V7)
		18351	Socket—6-contact tube socket (V1)
		33084	Socket—8-contact octal tube socket (V2, V3, V4)
		33001	Socket—11-contact magnal socket for cathode-ray tube (V5)
		33886	Switch—Horizontal amplifier switch (S3)
		33887	Switch—Range switch (S5)
		33885	Switch—Safety interlock switch (S1)
		33868	Switch—Sync switch (S4)
		33869	Switch—Vertical amplifier switch (S6)
		33884	Transformer—105-125 V, 60 cycle power transformer (T1)
		14119	Transformer—Synchronizing transformer (T2)

Replacement Parts supplied are within Engineering Specification Tolerances.

43-30-4

Trademarks "VoltOhmyst," "Radiotron," "Chanalyst," Reg. U. S. Pat. Off. by RCA.

Printed in U. S. A.



## CATHODE-RAY OSCILLOGRAPH

STOCK No. 158

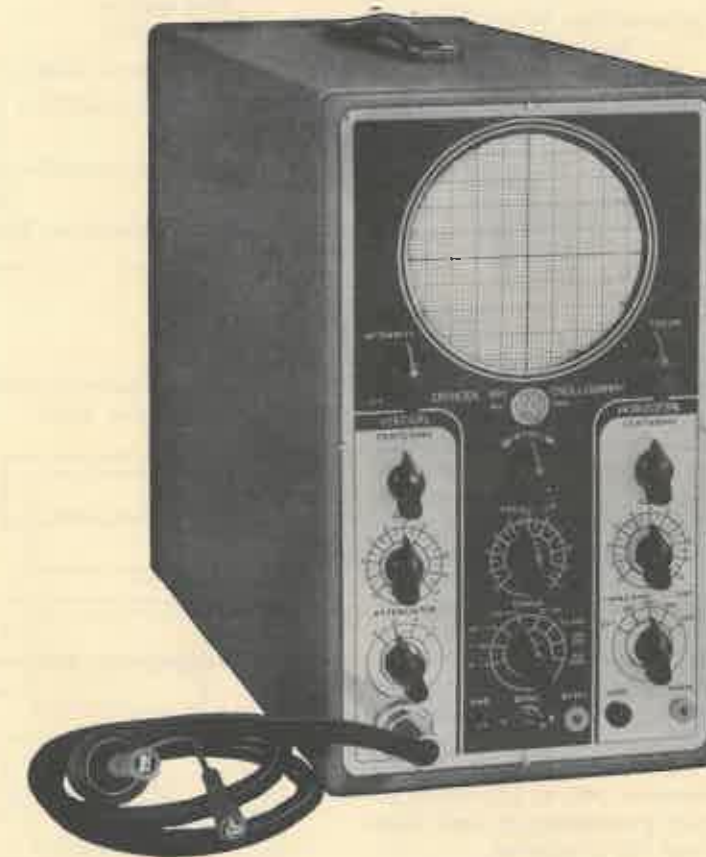

RADIO CORPORATION OF AMERICA

Camden, New Jersey, U. S. A.



# Cathode-Ray Oscillograph

Stock No. 158

## TECHNICAL SUMMARY

### POWER SUPPLY:

Rating . . . . . 105-125 volts, 50-60 cycles  
(Specifications based on 117 volts, 60 cycles)  
Power Consumption . . . . . 55 watts  
Fuse Protection . . . . . 1 ampere

### TUBE COMPLEMENT:

R  
RCA-6C6 . . . . . Horizontal Amplifier  
RCA-6SJ7 . . . . . 1st Stage Vertical Amplifier  
RCA-1852 . . . . . 2nd Stage Vertical Amplifier  
RCA-884 . . . . . Timing Circuit Oscillator  
RCA-5BP1/1802-P1  
Cathode-Ray Tube (5 inch)  
RCA-80 . . . . . Low-voltage Rectifier  
RCA-879 . . . . . High-voltage Rectifier

### OVERALL DIMENSIONS:

Height (including carrying  
handle) . . . . . 14 $\frac{3}{8}$  inches  
Width . . . . . 8 inches  
Depth . . . . . 19 $\frac{1}{2}$  inches  
Weight (net) . . . . . 30 pounds

### OPERATING DATA (Gain Max.):

Deflection Sensitivity at Vertical Amplifier  
Input:  
With cable . . . . . 0.4 volts (r.m.s.) per inch\*  
Without Cable . . . . . 0.04 volts (r.m.s.) per inch\*

Frequency Response of Vertical Amplifier:  
Flat within . . . . . 1 db to 200 kc.\*  
Flat within . . . . . -3 db. to 500 kc.\*  
Useful range . . . . . 5 cycles to 1 mc.

Frequency Response of Horizontal Amplifier:  
Flat within . . . . . 1 db. to 45 kc.\*  
Flat within . . . . . -3 db. to 100 kc.\*

### Input Characteristics:

Vertical amplifier with cable  
1.15 megohms, 16 mmfd.  
Vertical amplifier without cable  
0.15 megohms, 38 mmfd.  
Timing Frequency Range . . 4 cycles to 18 kc.\*

\* Guaranteed values. Factory standards exceed these values.

## DESCRIPTION

The Stock No. 158 Cathode-Ray Oscillograph is a reliable instrument for the observation of electrical circuit phenomena. Although specifically designed for use in servicing television receivers, it is practically unlimited in application, some of its more common uses include the study of wave shapes and transients, measurement of modulation, adjustment of radio receivers and transmitters, determination of peak voltages, and tracing of vacuum-tube characteristics. Its major but not only advantage over older types of visual devices is its freedom from inertia, allowing the observation of very rapid changes of current or voltage without appreciable distortion. The instrument is entirely portable, as shown by the cover illustration, and operates from an a-c source of 105 to 125 volts, 50 to 60 cycles. An integral power-supply unit furnishes all voltages required for operation.

Figure 1 shows the essential units of the instrument in block diagram form.

The primary purpose of these instructions is to give the fundamentals of operation. As the use of cathode-ray apparatus becomes more widespread, many new applications will be found and a thorough understanding of these fundamentals will

enable the operator to readily adapt the equipment to his particular use.

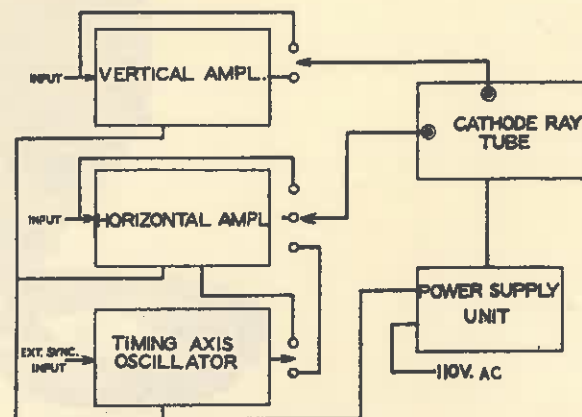

Figure 1—Block Diagram

For a comprehensive discussion of the fundamentals of cathode-ray tubes and an analysis of the figures which appear on the screen, see "A General Discussion of the Cathode-Ray Tube," RCA-IB-26453.

**WARNING**—A POTENTIAL OF 1500 VOLTS IS PRESENT AT THE CATHODE-RAY TUBE SOCKET AND AT OTHER POINTS ON THE CHASSIS. ALWAYS DISCONNECT THE POWER CORD BEFORE REMOVING THE CHASSIS FROM THE CABINET.

## INSTALLATION

Remove the screws at the rear of the case. Withdraw the chassis from the case, feeding the power cable through the hole in the back. Make certain that all tubes are firmly in their sockets and that all grid-cap connections are in place. Unpack the cathode ray tube and install it in its proper mounting and connect the socket, rotating the tube if necessary so that the socket key is located at the top. Replace the chassis in the case and replace the screws at the rear. With the "Intensity" control in the extreme counterclockwise ("Off") position, plus the power-supply cable

into an electrical outlet supplying 105-125 volts at 50-60 cycles. The instrument is then ready for operation.

NOTE: AN INTERLOCK SWITCH, LOCATED AT THE REAR OF THE CHASSIS, OPENS THE POWER CIRCUIT WHEN THE CHASSIS IS REMOVED FROM THE CASE. DO NOT ATTEMPT TO OPERATE THE EQUIPMENT WHILE WITHDRAWN FROM THE CASE AS THE HIGH POTENTIALS USED ARE DANGEROUS.

## OPERATION

### Controls

Refer to the schematic and wiring diagrams for the location of circuit units designated by symbols.

1. "Intensity" control (R-41) consists of a potentiometer located in the high side of the high-voltage bleeder and controls the bias on the grid of the cathode-ray tube, which in turn determines the quantity of electrons emanating from the "gun," thus controlling the spot size. The power switch (S2) is attached to this potentiometer. Initial clockwise rotation of this control closes the switch and additional rotation increases the spot size.

2. "Focus" control (R-43) is a potentiometer located in the high-voltage bleeder. Its position controls the No. 1 anode voltage, which, with constant voltage on anode No. 2, determines the distance at which the electron beam focuses. In general, for a given "Intensity" setting, the "Focus" control should be set for maximum distinctness of spot or image.

3. "Vertical Amplifier" switch (S-6) is an input attenuator in the grid circuit of the first amplifier stage. The attenuation steps are approximately 1:5. Connection to the input is made through a special cable which may be omitted if higher input capacity is permissible. An increase in sensitivity of approximately 10 to 1 is obtained without the cable. Input connection, in this case, is made to terminal #2 of the input jack.

4. "Horizontal Amplifier" switch (S-3) has five positions: The amplifier "On" and "Off" and three "Timing" positions. On all "Timing" positions the "saw-tooth" or timing-axis oscillator feeds through an amplifier to the horizontal deflecting plates of the cathode-ray tube. At "On," the "Horizontal" phone tip jacks are connected through an amplifier to these deflecting plates while at "Off," the phone tip jacks are connected straight through to the deflecting plates. In both of the latter two cases, there is a series condenser in the input circuit.

5. "Vertical Gain" control (R-33) consists of a potentiometer located in the grid circuit of the 2nd stage of the vertical amplifier. With the

"Vertical Amplifier" switch set for any given position this potentiometer controls the vertical deflection. By advancing the "Vertical Amplifier" switch from a lower to the next largest number the sensitivity is cut approximately 5 to 1.

6. "Horizontal Gain" control (R-2) consists of a potentiometer located in the input circuit of the horizontal amplifier. With the "Horizontal Amplifier" switch set at "Timing" or "On," this potentiometer controls the horizontal deflection. Due to the capacity load on this input potentiometer, when operating on "Timing" at the higher audio frequencies, linear sweep will not be obtained at all setting of this control. For best results, the control should be set for maximum linearity.

7. "Range" switch (S-5) selects one of eight timing capacitor values. It thus changes the timing-axis oscillator frequency in steps, giving eight ranges approximately as shown on the front panel.

8. "Freq." control (R-12) is a rheostat connected in series with the timing condenser. It changes the timing-axis oscillator frequency gradually as it is rotated, and in conjunction with the "Range" switch gives a continuous range between the extremes of frequency.

9. "Sync." control (R-6) is a potentiometer used to control the amount of synchronizing voltage fed to the grid of the RCA-884 tube. In general, it should be set as far counterclockwise as is consistent with a locked image, since over-synchronization results in a poor wave-form produced by the timing-axis oscillator.

10. The "Sync." switch provides for a 180-degree phase shift of the image on the screen.

11. "Horizontal Amplifier" switch (S-3) has three timing positions, "Int.," "60," and "Ext." for synchronization. At "Int.," the voltage drop across resistor R-5 in the plate circuit of the vertical amplifier is fed through the "Sync." control and input transformer to the grid of the RCA-884 tube. Thus, the timing-axis oscillator can be synchronized with the signal on the vertical axis at the fundamental frequency or at any sub-multiple, such as  $\frac{1}{2}$ ,  $\frac{1}{3}$  . . . Synchronization is not effective if it is attempted to operate the timing-axis oscillator at

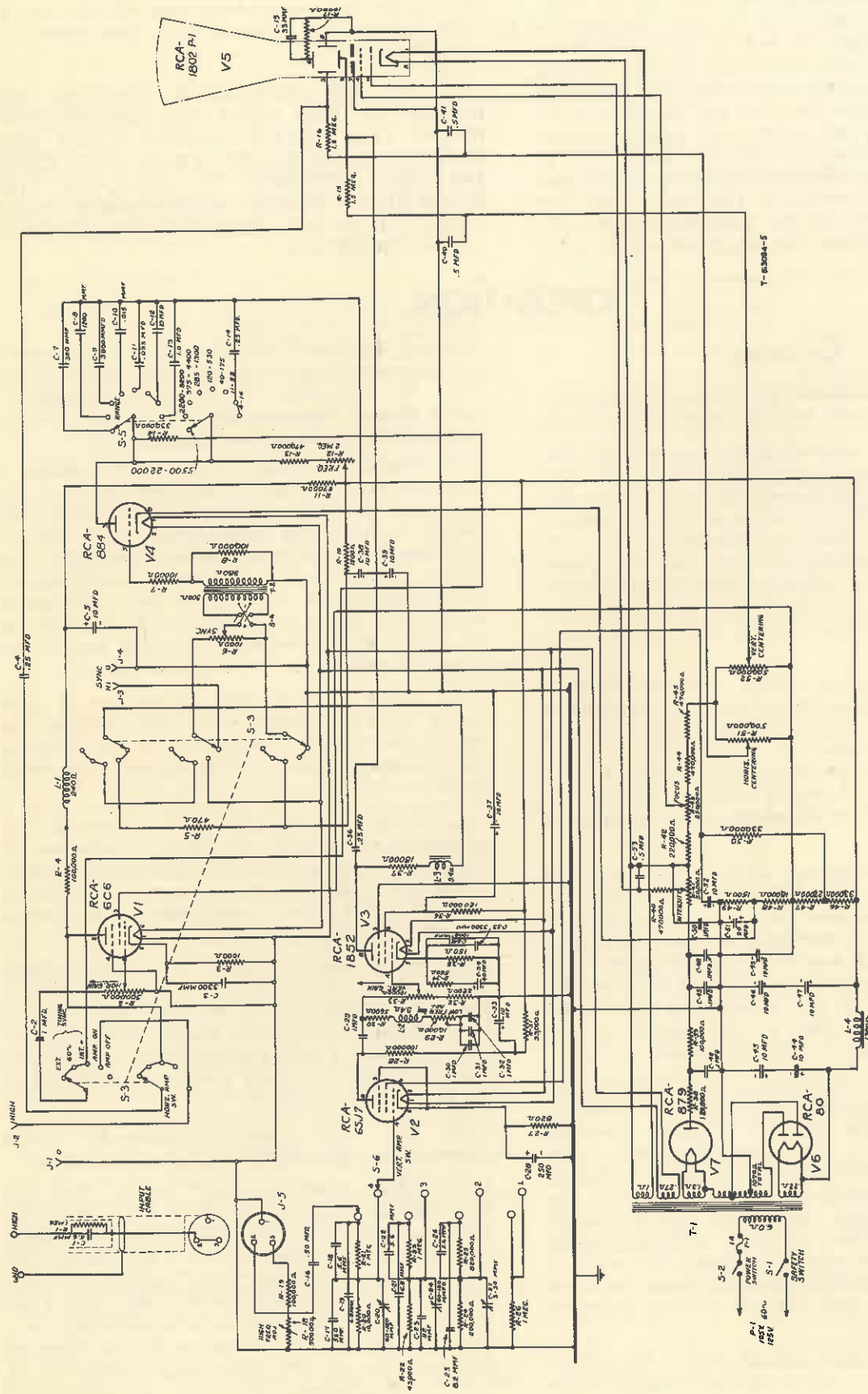

Figure 2—Schematic Circuit Diagram, Stock No. 158

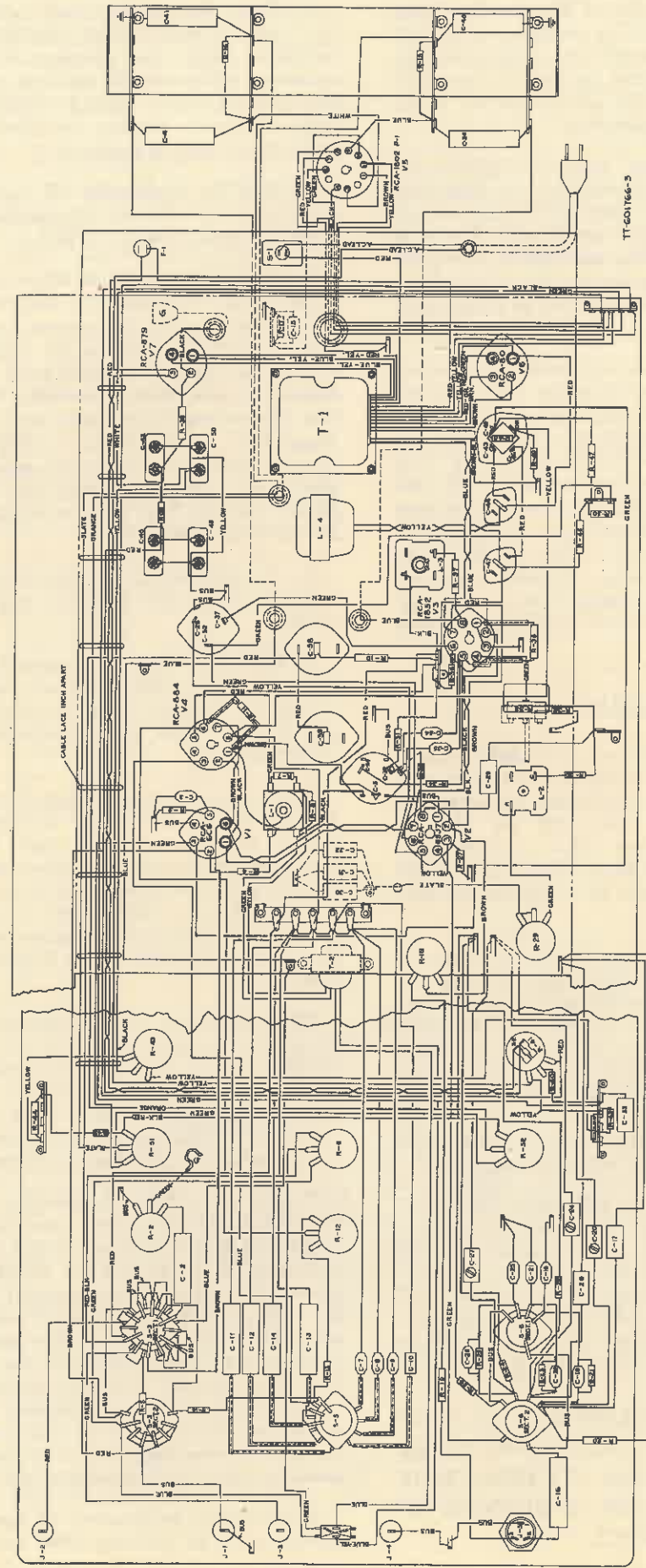

Figure 3—Chassis Wiring Diagram, Stock No. 158



a higher frequency than that of the synchronizing voltage. When set to "60" a portion of the 60 cycle filament voltage is used for synchronization. On "Ext.," the "Sync." phone tip jack is connected to the "Sync." control. This allows the use of an external source for synchronizing.

12. The two "centering" controls regulate the amount of d-c potential between the two deflecting plates of each pair, and thereby allows adjustment of the position of the spot or image. There is sufficient voltage across these controls to move the spot approximately two inches on the screen. Start with both of these controls adjusted at about mid-position.

13. There are four phone tip jacks provided on the panel. A voltage applied to the "Horizontal" jacks, with the horizontal amplifier switch S-3 in the "On" position, will result in a horizontal deflection of the spot. The "Sync." phone tip jack is used for external synchronization of the saw tooth oscillator. Caution: Do not apply more than 15 (r.m.s.) volts to "Ext. Sync." jack or damage to input components may result. The "Gnd." jacks are connected to the chassis. A switch labeled "Sync." controls the synchronization of the saw tooth oscillator with the source on either positive or negative impulses.

## Applications

The following procedures are included in order to familiarize the operator with the operations and connections involved in particular applications. All applications of the equipment are not described, but analysis of any other problem will show wherein it is similar to or differs from those given, enabling the operator to work out his own sequence of operation.

As has been pointed out previously, most applications of this instrument are performed with the output of the unit under test connected to the vertical plates of the cathode-ray tube, and the wave shape studied by application of known constants on the horizontal plates of the tube. Before any measurements are attempted, the operator is urged to go through the following procedure in order to familiarize himself with the controls and their location and to get the "feel" of their operation:

1. Connect the power plug to an a-c source of 110/120 volts, 50/60 cycles. Turn the "Intensity" control clockwise, causing a spot to appear on the screen, increasing in size as the "Intensity" control is advanced further clockwise. The "Focus" control should then be adjusted until maximum distinctness of the spot or image occurs. The centering controls should be set about mid-position.

**CAUTION. DO NOT ALLOW A SMALL SPOT OF HIGH BRILLIANCY TO REMAIN STATIONARY ON THE SCREEN FOR ANY LENGTH OF TIME, AS DISCOLORATION OR BURNING OF THE SCREEN WILL RESULT.**

With the spot on the screen and with the "Intensity" control retarded so that the spot is not too brilliant, adjust the position of the spot to the center of the screen by rotation of the two centering controls. After initial adjustment, these controls will rarely require re-adjustment, unless the cathode-ray tube is replaced.

To turn the equipment off, turn the "Intensity" control to its extreme counterclockwise position, until a distinct "snap" is heard.

2. Apply a source of 60-cycle current to the input cable. To adjust the length of the resultant line appearing on the screen, turn the "Attenuator" switch to one of its four positions and adjust the "Gain" control until the length is as desired. Application of the same 60-cycle source to the "Horizontal" pin jacks with the "Horizontal Amplifier" switch "On" or "Off" will similarly show a horizontal line on the screen, the length of which may be varied (with the "Horizontal Amplifier" switch "On") by manipulation of "Horizontal Gain" control.

3. To expand (2) further, have 60 cycles available at both "Horizontal" and "Vertical" terminals.

**CAUTION.** Since all ground or "Gnd" pin jacks on the oscillograph are common, it is advisable to use an isolating transformer for one supply, so that there is no common connection between the two.

Apply the horizontal 60-cycle supply to the deflecting plates, preferably through the amplifier and its gain control, then apply the 60-cycle vertical supply through the other amplifier and its gain control. The result will be a diagonal line. Horizontal amp. switch must be turned to "on" to do this (see "A General Discussion of the Cathode-Ray Tube," RCA-IB-26453, Figure 5 and explanation.)

**AC VOLTMETER WITH AMPLIFIER**—For this application, the characteristics of the unit are as follows: Input resistance—1.1 megohm, input capacity—approximately 8 mmfs; voltage range—approximately 175 volts (higher with external attenuator); calibration—approximately 0.64 peak volts per inch or 0.4 r-m-s volts per inch.

**Procedure**—Make connections and adjust controls. With the "Vertical Gain" control in the extreme clockwise position, a line one inch long is obtained on the screen for about 0.64 peak volts input. Intermediate positions of the gain control give different calibrations, of course, and if considerable use is made of this feature, it may be advisable to plot a curve of the inputs required to give a one-inch deflection at various intermediate positions of the gain control. If working at a frequency above 10,000 cycles, it must be remembered that retarding the gain control from maximum impairs the linearity of the amplifier.

A particular application of operation as an a-c voltmeter is in making hum measurements in a

power supply unit. In this case, the "Gnd." pin jack or cable ground lead ("Vertical") is connected to the common lead of the filter circuit of the unit under test and the input cable is used to check the a-c ripple present at the various circuit component terminals.

**AUDIO QUALITY MEASUREMENTS**—Use of the "saw-tooth oscillator" feature of the oscillograph provides a check which cannot be made with an ordinary voltmeter. This is extremely helpful in determining the audio quality of a receiver or similar instrument and also in locating causes of audio distortion.

**Procedure**—Apply the output from a constant frequency record or audio oscillator to the input cable. Turn the "Range" switch to that tap giving a range including the frequency of the input signal and adjust the "Freq." control until the saw-tooth oscillator frequency is near that of the input signal. If the two frequencies are identical, one cycle of the input signal will be observed on the screen; if the saw-tooth oscillator frequency is one-half that of the input signal, two cycles of the latter will appear; if one-third, three cycles, etc. Next, connect this constant frequency record or audio oscillator output to the audio input of the unit under test and connect the output of the unit under test to the input cable of the oscillograph. If the resultant wave does not correspond to that obtained when the input was direct to the oscillograph, audio distortion is present.

If it is desired to measure the overall audio fidelity of a receiver, for instance, the procedure is similar to that above except that the voltage modulating an r-f oscillator is fed into the oscillograph, adjusted as above. Then the modulated oscillator is connected to the r-f input terminals of the receiver and the loudspeaker voice coil connected to the oscillograph. Comparison of the two resultant waves will indicate how much distortion occurs in the receiver under test. Observing the quality of the input to the receiver from the test oscillator will also show how much distortion is being fed into the receiver from the test oscillator. This is desirable since it may show that all the distortion present in the receiver output may not be due to the receiver characteristics, but to those of the test oscillator (assuming no distortion from modulation).

**MODULATION INDICATOR**—(1) One method of measuring the modulation of a transmitter is to place the modulated r-f output of the transmitter into the vertical plates of the cathode-ray tube and the audio input signal to the transmitter on the "Sync." pin jack.

**Procedure**—Connect a constant-frequency input to the transmitter and connect a small pickup coil, located near the transmitter tank coil, to the input cable. The pickup on this coil should be from 1.2-10 volts. Connect the "Sync." pin jacks of the oscillograph to the transmitter audio amplifier at a point providing a 2- to 4-volt signal.

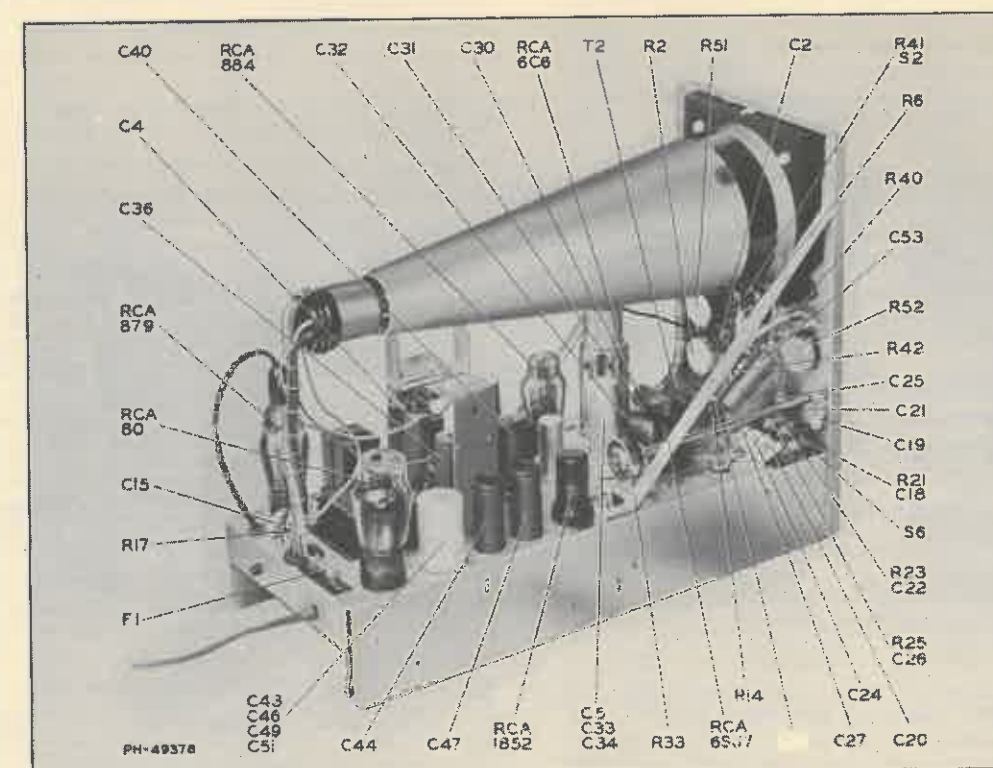

Figure 4—Top View of Chassis



Set "Horizontal Amplifier" switch to "Ext." position. Turn the "Range" switch to the tap which includes the frequency of the input signal and adjust "Freq." control until the saw-tooth oscillator interlocks with the signal on the vertical plates. Adjustment of the "Sync." control provides control of the voltage from the audio amplifier to the grid of the RCA-884 tube. Adjustment of "Horizontal Gain" control varies the horizontal deflection.

(2) Another and somewhat similar method of modulation measurement is to connect the pickup coil to the input cable as before, but connect the audio signal (from the transmitter audio amplifier) to the "Horizontal" pin jacks. Adjust "Horizontal Gain" control until desired horizontal deflection is obtained. The percentage modulation can then be readily determined. See Figure 31, "A General Discussion of the Cathode-Ray Tube," RCA-IB-26453.

**ALIGNMENT OF INTERMEDIATE-FREQUENCY STAGES**  
—For alignment of the intermediate-frequency stages of a receiver, it is essential that an auxiliary apparatus, a frequency modulator, be available to sweep the intermediate frequency for which the receiver is designed. One type of frequency modulator consists of sweep condenser and a synchronizing generator rotated in synchronism by a driving motor. The condenser is arranged to "sweep" the frequency of the r-f input to the receiver (or i-f stages) and the synchronizing generator connects to the "sync." jack of the oscillograph so as to synchronize the saw-tooth oscillator with the fre-

quency variation of the test oscillator input to the receiver. An electronic sweep test oscillator may be used to provide both a frequency-modulated signal and a synchronizing signal, so that no other frequency modulator is required.

The test oscillator output should be coupled to the grid of the tube preceding the i-f stage under alignment. It is essential that this connection be made without altering any of the operating characteristics of this stage. If the grid of the tube to which connection is to be made is at zero d-c potential with respect to ground, connect the oscillator to the grid of the tube and disconnect the lead normally on the grid, the low side of the test oscillator output returning to chassis ground. If the grid is not at zero d-c potential with respect to ground, connect the high side of the oscillator to the grid (disconnecting the lead on the grid) and the other side to the "—C" lead for this grid.

The "Vertical" input cable of the oscillograph should be connected to the audio output of the second detector. For a diode detector, this connection may be across the volume control alone or across both the volume control and automatic volume control resistor, if this connection is convenient. When the second detector is a triode, tetrode or pentode, resistance-coupled to the first audio stage, the connection to the input cable may be to the plate of the tube, the "Gnd" lead being connected to ground. In the case of a triode, tetrode or pentode, transformer- or impedance-coupled to the first audio stage, connect a resistor

of approximately 20,000 ohms in series with the plate of the tube and by-pass the inductance in the plate circuit by a 1.0 mfd or larger capacitor. This changes the impedance of the plate circuit to resistance rather than inductive reactance; the input cable should be connected to the plate of the tube and the "Gnd." lead to ground in order to take the audio voltage off his resistor.

**ALIGNMENT OF RADIO-FREQUENCY STAGES**—The equipment used for r-f alignment is identical to that for i-f alignment, except that the test oscillator output is connected to the antenna lead of the receiver, and different frequencies are employed.

**FREQUENCY MEASUREMENTS**—In using the oscillograph for frequency measurement, either Lissajou figures (sine waves on both axes) may be used, or the linear timing axis may be employed on the horizontal axis. The most flexible method for frequencies up to 100,000 cycles is the linear timing axis method. The frequency stability of the saw-tooth oscillator running free is not good enough to depend upon for accurate measurements, but when this oscillator is synchronized with a standard-frequency voltage, its frequency stability is the same as that of the standard, and it can be synchronized at any sub-multiple of the

standard frequency down to about one-tenth. This allows convenient calibration of a device at many points between one-hundredth of—and ten times a single standard-frequency source, and every point is as accurate as the standard. If a 1000-cycle standard source is used, calibration points between 10 and 10,000 cycles are easily obtained. Using Lissajou figures, calibration points between 100 and 10,000 cycles can be obtained. A frequency standard which is almost universally available is the 60-cycle a-c supply. Since the advent and rapid spread of electric clocks, the frequency of nearly all commercial power is held to a very close tolerance. This allows accurate calibration at frequencies up to about 600 cycles. "Sync." switch S-4 reverses the input to the saw-tooth oscillator and in so doing provides synchronization with impulses of opposite polarity.

**CHECKING PHASE SHIFT**—To check phase shift of electrical equipment with the oscillograph, observe the screen pattern with the input to the equipment connected to the "Horizontal" jacks and the output from the equipment connected to the input cable. If no phase shift exists, a sloping straight-line image will appear. The internal amplifiers in the oscillograph introduce some phase displacement which must be considered.

## CIRCUITS

The schematic arrangement of the entire circuit is shown in Figure 2.

An amplifier consisting of two stages constitutes the means of obtaining gain for the signal applied to the vertical deflecting system. The input to this stage is a high-resistance step attenuator connected to provide stepped gain control. An isolation capacitor is made a part of the input circuit to exclude from the grid any direct current which may be associated with the circuit being observed. The plate circuit of the output tube (RCA-1852) is composed of two elements in series, a resistor and an inductance whose values are so designed as to effect a broad and uniform frequency response in the amplifier stage. Coupling from the amplifier plate to the cathode-ray tube is made through a capacitor.

The amplifier for the signal applied to the horizontal deflecting plates is a single stage. A switch is provided to disconnect the Horizontal Amplifier, thereby applying the voltage to be studied directly to the deflecting plate. Extra contacts are used on the input switch to the horizontal amplifier for feeding in the timing or "saw-tooth" oscillator signal.

A synchronization system is included, as shown in the input circuit of the RCA-884. This is included in the Horizontal Amplifier switch and is described under "Operation." The timing axis oscillator stage, using the RCA-884, is designed to have a frequency range of approximately 4-18,000 cycles, controlled through the "Range" switch and "Frequency" control. The signal from this oscillator has a "saw-tooth" wave shape, obtained as

follows: A d-c potential is applied across a capacitor and resistor in series in the plate circuit of the RCA-884 tube. This voltage charges the capacitor until the ionization potential (plate voltage at which the gas in the tube ionizes) is reached. When the RCA-884 ionizes, the capacitor is short-circuited and the voltage across it drops nearly to zero. The tube immediately de-ionizes and allows the capacitor to start charging again. In this manner, the voltage across the capacitor has a "saw-tooth" characteristic. The capacitor referred to above is selected by the position of the "Range" switch as described in "Operation." With the "Horizontal Amplifier" switch on "Timing," the voltage across this capacitor passes through the horizontal amplifier to the plates of the cathode-ray tube. The operation of the "Sync." control, in the grid circuit of the RCA-884 is described under "Operation."

The cathode-ray tube is described under "General Discussion of Cathode-Ray Tube," RCA-IB-26453. Controls used to alter the intensity, focus and zero adjustments are described under "Operation."

Power required for operation of the instrument is obtained through the power unit from a 110- to 120-volt, 50- to 60-cycle supply. Voltage rectification is accomplished by one RCA-80 and one RCA-879 rectifier tube, one being used full-wave and the other half-wave. One of these tubes supplies plate voltages for the amplifier stages and sweep oscillator, filtered through a reactor-capacitor combination. The other supplies the high voltage to the cathode-ray tube for polarization purposes.

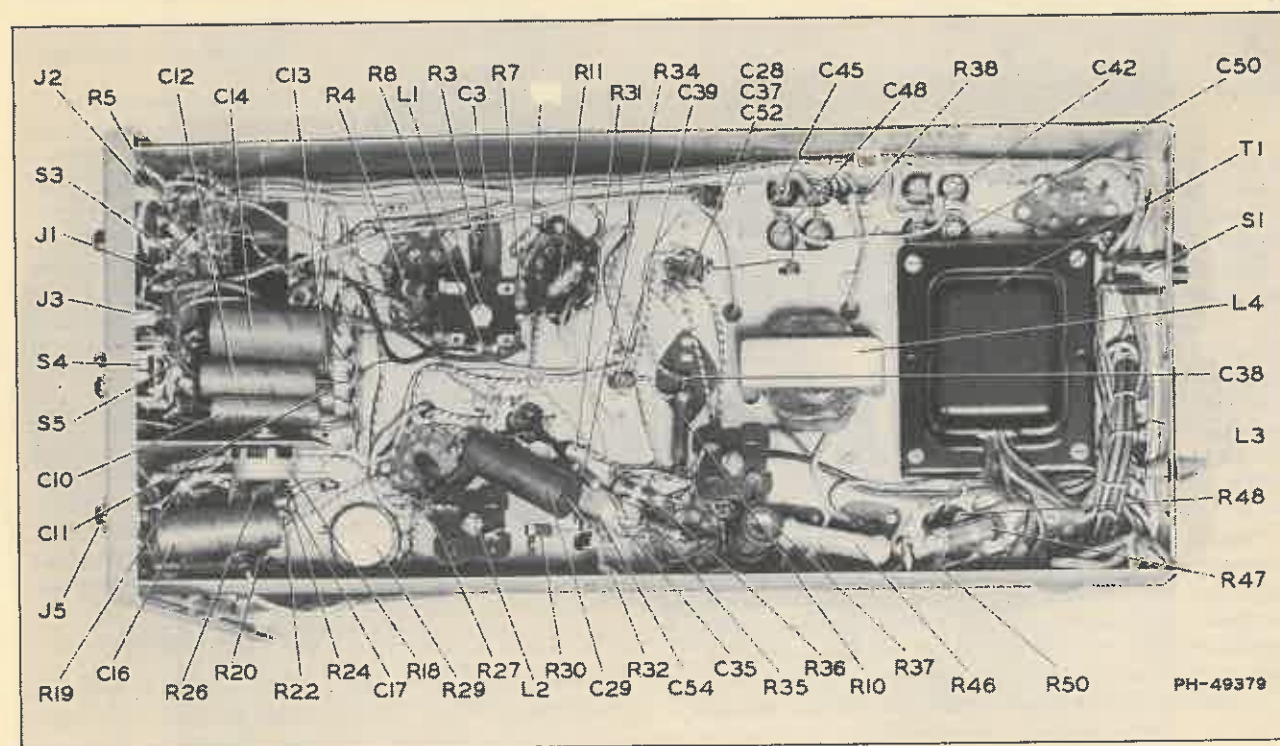

Figure 5—Bottom View of Chassis



## MAINTENANCE

Under ordinary circumstances no adjustments need be made on the instrument but if these are disturbed they can be readjusted only with the use of square wave inputs obtained from a reliable square generator. Normally this means returning the instrument to the factory.

### Radiotrons

Under ordinary usage within the ratings specified for voltage supply, tube life will be consistent with that obtained in other applications. The amplifier, oscillator and rectifier tubes will wear in accordance with loss of emission; where as the determining factor in the life of the cathode-ray tube is the deterioration of the fluorescent screen. It is therefore advisable to avoid leaving a bright, concentrated "spot" on the screen. Also, the image of the phenomena under observation should be removed from the screen when not actually being studied or measured; this item of care will enable a long and useful life to be obtained from the tube.

It is ordinarily not possible to test the Radiotrons in their respective sockets, due to the likelihood of circuit effects causing error. However, through the use of the RCA Chanalyst, amplifier tubes may be checked while in their circuits and under operating conditions by the signal-tracing method.

The tubes may also be removed and checked with standard tube testing apparatus or the questionable tube may be replaced with one known to be in good condition.

On the cathode-ray tube, excessive wear and approach to its limit of life is indicated by inability to obtain a satisfactory focus, and also by the screen becoming streaked and spotted. When it becomes necessary to install a new cathode-ray tube, some rotational adjustment may be required to bring the axes of deflection into their proper horizontal and vertical planes. This is accomplished by loosening the wing nut on the cathode-ray tube shield clamp, rotating the socket as desired, and then tightening the wing nut.

### Fuse Replacements

A small 1-ampere cartridge fuse is used in the primary circuit of the power transformer. This fuse is intended for protection of the entire power system of the oscillograph, and, therefore, should not be replaced by one having a higher rating, nor be shorted out. A fuse failure should be carefully investigated before making a replacement, since

with fuses of accepted quality, there usually will be a definite cause for the breakdown. The cause may originate from a surge in the power-supply line, but the greater percentage of causes may be centered in the apparatus protected, such as shorted rectifier elements, and so forth. Occasionally, a fuse may open from heat generated at one of its clip contacts. These points should therefore be kept clean and in secure contact with the fuse.

### Resistance and Continuity Tests

The chassis wiring layout giving color code and physical relation of the parts is shown in Figure 3. All resistor and capacitor values are given to facilitate a rapid and sure test for continuity of circuit and the condition of same. Coils and transformer windings have their d-c resistances shown.

*In working on the chassis of the oscillograph, care must be observed to have the power supply completely disconnected. The high voltages associated with the circuits of the cathode-ray tube make it especially dangerous to attempt to handle or work on the chassis while the power is "On."*

Care should be exercised in replacing any part that may be found faulty. All wiring associated with the part involved must be removed, and especial attention given to the possibility of damage to other wiring or parts. The relation of wiring and parts should be the same as in the original assembly. The insulation and spacing of the high-voltage leads is very necessary and an important item to be adhered to in servicing of the instrument.

### Voltage Measurements

One means of learning the condition of operation and tracing the circuit faults of the oscillograph is by checking the values of the voltages and currents at the Radiotron sockets. The normal values, which can be expected to be found when the instrument is working properly under the specified power rating, are indicated by the Radiotron Socket Voltage Table. In general, the values shown are measured from the socket contacts to ground; however, the heater or filament voltages are a-c and appear between the F-F or H-H clips. All readings given are actual operating values, and do not allow for any errors likely to be caused by current drain of the measuring instrument.

## TUBE SOCKET VOLTAGES

Approximate tube socket voltages read with respect to ground: (Measured with RCA VoltOhmyst). 115 volts applied to primary.

Tube	Function	$E_f$	$E_k$	$E_g$	$E_{gg}$	$E_{sup}$	$E_p$
RCA-6C6	Horizontal Amplifier		+1.8 to +27		+102 to +105	0	+232 to +330
RCA-6SJ7	Vertical Amplifier (1st Stage)		+2.4		+73	+2.65	+195
RCA-1852	Vertical Amplifier (2nd Stage)		+1.9		+157	0	+260
RCA-884	Sweep Oscillator		+7 to +9				+53
RCA-879	High-Voltage Rectifier	AC1190					-1165
RCA-80	Low-Voltage Rectifier	+520					AC435
Tube	Function	$E_f$	$E_g$	Deflection Plate		1st Anode	2nd Anode
RCA-1802 P-1	Cathode-Ray Tube	-850 to -960	-845 to -925	No. 3 +88 to -72	No. 9 +88 to -72		

**R. C. A.** stock #18000 replacement condenser for C 42, C 45, C 48 and C 50, is electrically equivalent to condensers used in this particular instrument. When replacing use strap mounting on side of chassis.

(158)